

The ENUBET project

A. Longhin (Padova University and INFN)
on behalf of the ENUBET Collaboration

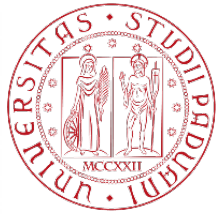

Strasbourg, 5-6 Nov 2018

This project has received funding from the European Research Council (ERC) under the European Union's Horizon 2020 research and innovation programme (G.A. n. 681647).

ENUBET: 52 physicists, 11 institutions



Monitored beams



Based on conventional technologies, aiming for a **1% precision** on the ν_e flux

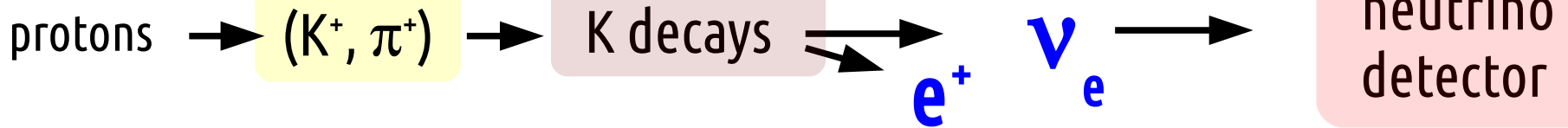

- Monitor (~ inclusively) the **decays in which ν are produced**
- “By-pass” **hadro-production, PoT, beam-line efficiency** uncertainties

• Fully instrumented decay region

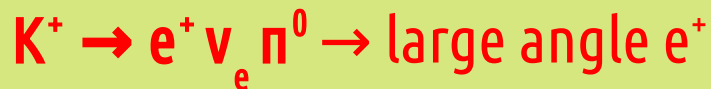

- ν_e flux prediction = **e^+ counting**

Removes the leading source of uncertainty in ν cross section measurements

To get the correct spectra and avoid swamping the instrumentation \rightarrow needs a **collimated momentum selected hadron beam** (only decay products in the tagger)
 \rightarrow Correlations with interaction radius allows an **a priori knowledge of the ν spectra**

Neutrino beams for precision physics: the ERC ENUBET project

The next generation of **short baseline** experiments for **cross-section** measurements and for **precision ν physics** (e.g. sterile ν and NSI) should rely on:

- ✓ a **direct measurement of the fluxes**
- ✓ a narrow band beam: **energy known a priori** from beam width
- ✓ a beam covering the region of interest from **sub- to multi-GeV**

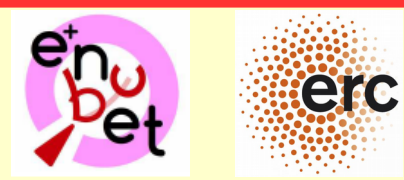

**Enhanced NeUtrino
BEams from kaon TAgging**

ERC-CoG-2015, G.A. 681647
(2016-21)

PI A. Longhin, Padova
University, INFN

The ENUBET facility fulfills simultaneously all these requirements

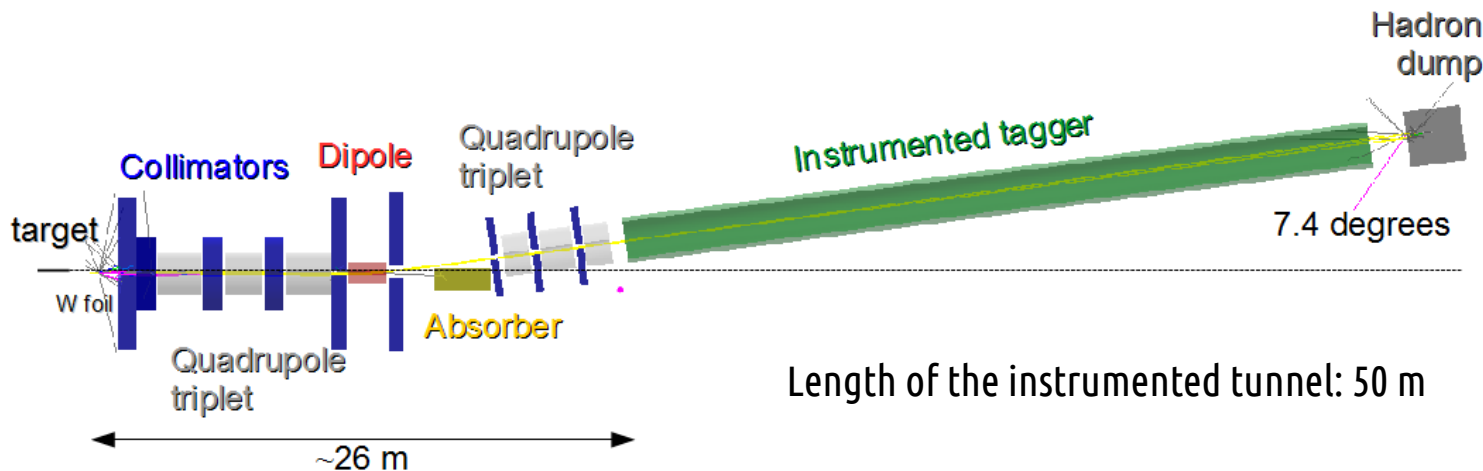

~ 500 t neutrino
detector @ 100 m
from the target

e.g. ICARUS@FNAL
or ProtoDUNE-
SP/DP@CERN

ENUBET goals and highlights

Goal: demonstrate the technical feasibility and physics performance of a neutrino beam where **lepton production at large angles is monitored at single particle level.**

Two pillars:

- Build and test with data a **demonstrator** of the instrumented decay tunnel
- Design/simulate the layout of the **hadronic beamline**

Recent **achievements**

- **end-to-end simulation** of the hadronic beamline
- Updated **physics performance**
- Experimental results on the beamline **instrumentation prototypes**

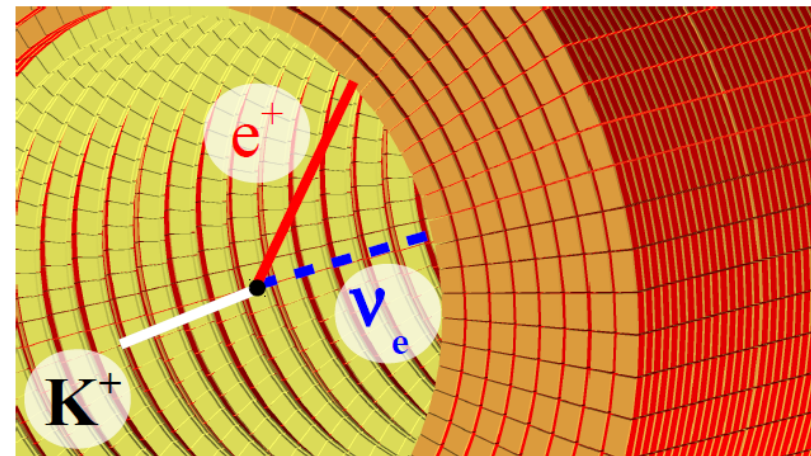

The ENUBET beam line

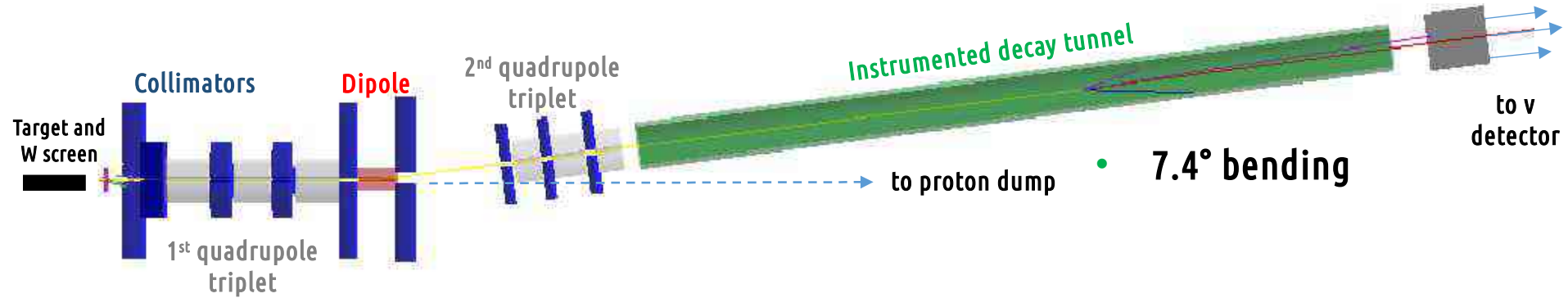

- **Proton driver:** CERN (400 GeV), FNAL (120 GeV), J-PARC (30 GeV)
- **Target:** 1 m Be, graphite target. FLUKA.
- **Focusing**
 - **Horn:** 2 ms pulse, 180 kA, 10 Hz during the flat top *[not shown in fig.]*
 - **Static focusing system:** a quadrupole triplet before the bending magnet
- **Transfer line**
 - Optics: optimized with **TRANSPORT** to a 10% momentum bite centered at 8.5 GeV/c
 - Particle transport and interaction: full simulation with **G4Beamline**
 - **Normal-conducting magnets**
 - 2 quad triplets (15 cm wide, $L < 2$ m, $B = 4$ to 7 T/m)
 - 1 bending dipole (15 cm wide, $L = 2$ m, $B = 1.8$ T)
- **Decay tunnel**
 - Radius: 1 m. Length: 40 m, low power hadron dump at the end of the decay tunnel
- **Proton dump:** position and size under optimization

The ENUBET beam line – particle yields



Focusing system	π/pot (10^{-3})	K/pot (10^{-3})	Extraction length	n/cycle (10^{10})	K/cycle (10^{10})	Proposal ^(c)
Horn	97	7.9	2 ms ^(a)	438	36	x 2
“static”	19	1.4	2 s ^(b)	85	6.2	x 5

(a) 2 ms at 10 Hz during the flat top (2 s) to empty the accelerator after a super-cycle.

(b) Slow extraction. Detailed performance and losses currently under evaluation at CERN

(c) [A. Longhin, L. Ludovici, F. Terranova, EPJ C75 \(2015\) 155.](#)



Advantages of the static extraction:

- No need for fast-cycling horn
- Strong reduction of the rate in the instrumented decay tunnel
- Monitor the μ after the dump at % level (flux of ν_μ from π) [**NEW: under evaluation**]
- Pave the way to a “**tagged neutrino beam**”, namely a beam where the neutrino interaction at the detector is **associated in time** with the observation of the **lepton from the parent hadron in the decay tunnel**

The ENUBET beam line: horn-based option

- Machine studies @ SPS are currently on-going:

Preliminary studies Jul/Aug 2018
 CERN-BE-OP-SPS, Velotti, Pari, Kain, Goddard

Slow extraction is induced by going to the third integer betatron resonance with a periodic pattern

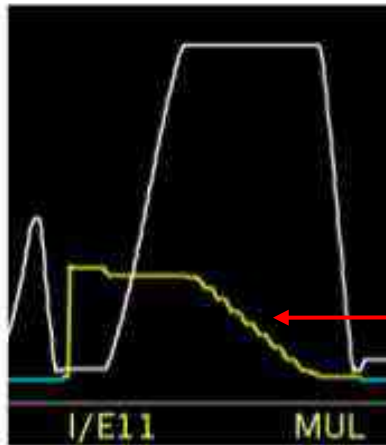
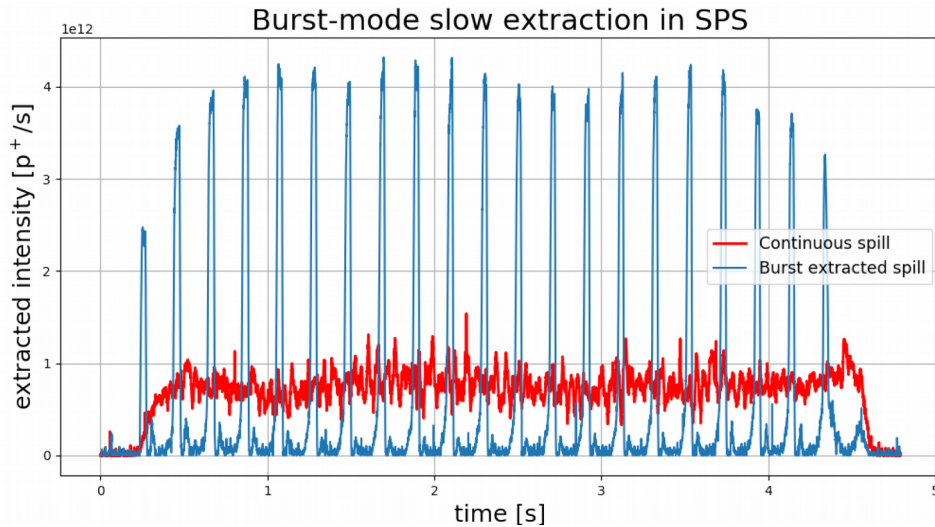
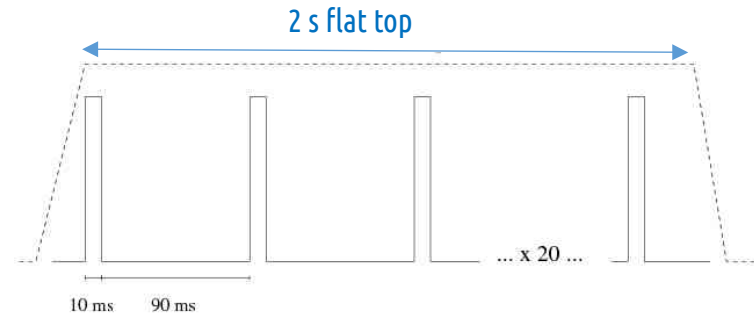

Proton current steps in correspondance of bunches

- Beam bunches in time with horn pulses
- Further studies** → understand radiation losses. Iterative corrections. Sextupoles: sharper bursts.

Proton current

The static beamline: emittance, particle content

Divergence of the kaon beam

K^+ @ tagger entrance

exit

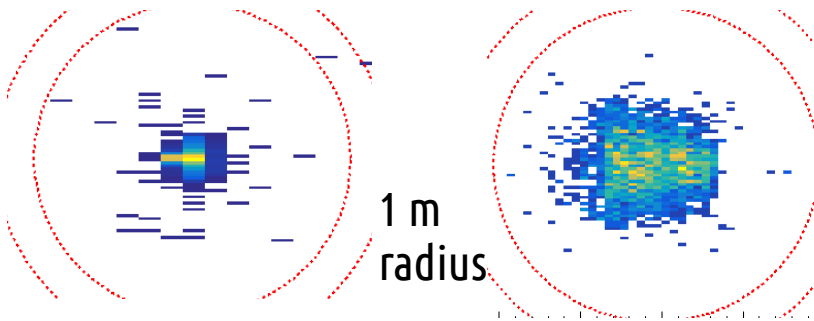

Particle budget @ tagger entrance

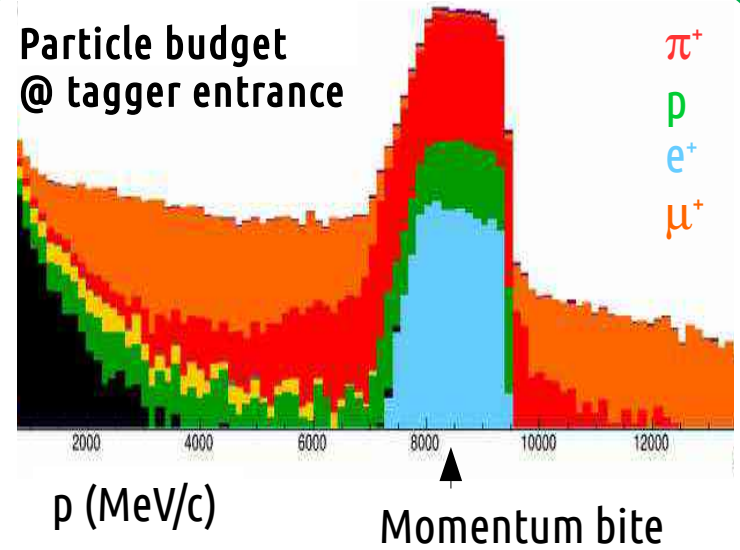

Spectra @ tagger entrance and exit

Low energy
high angle π

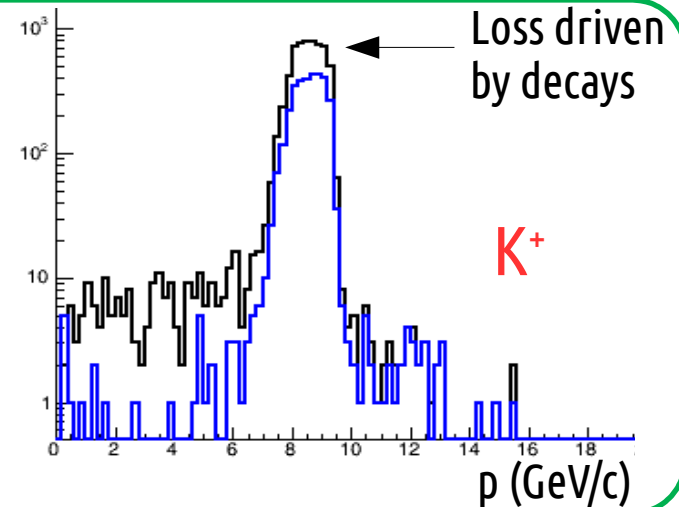
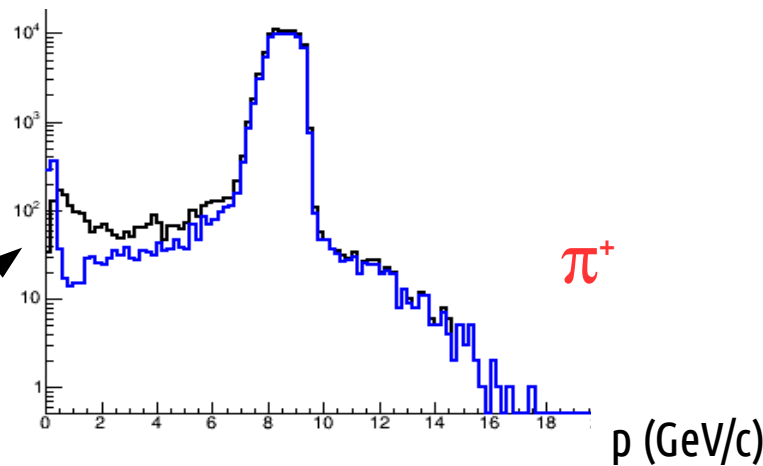

The static beamline: FLUKA simulation

Assess the specs of rad-hard upstream focusing quadrupoles

Optimize shielding to:

- reduce halos in the tagger region
- suppress the decays of off-momentum mesons out of tagger acceptance

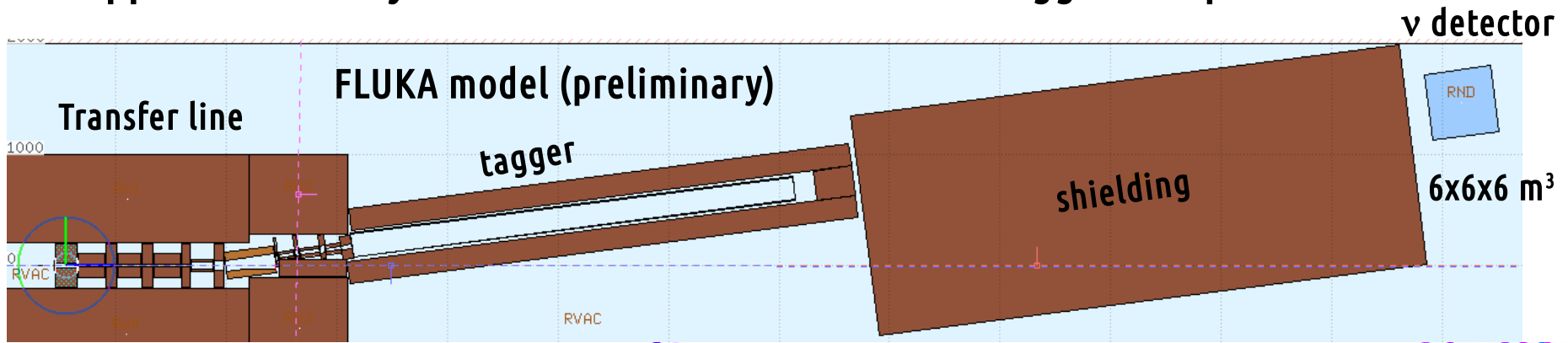

E deposition. 400 GeV/c p on target

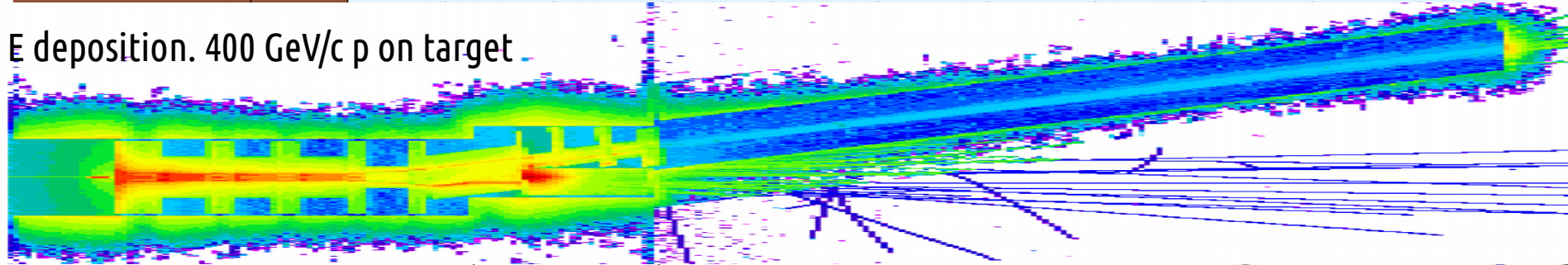

Energy deposition (π^+ only)

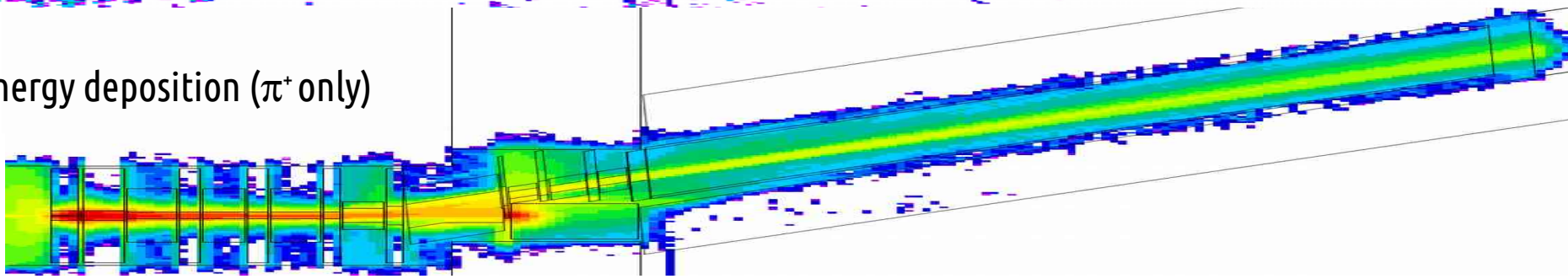

The ENUBET tagger

Ultra Compact Module
 $3 \times 3 \times 10 \text{ cm}^3 - 4.3 X_0$

Calorimeter

Longitudinal segmentation
 Plastic scintillator + Iron absorbers
 Integrated light readout with SiPM

→ $e^+/n^{\pm}/\mu$ separation

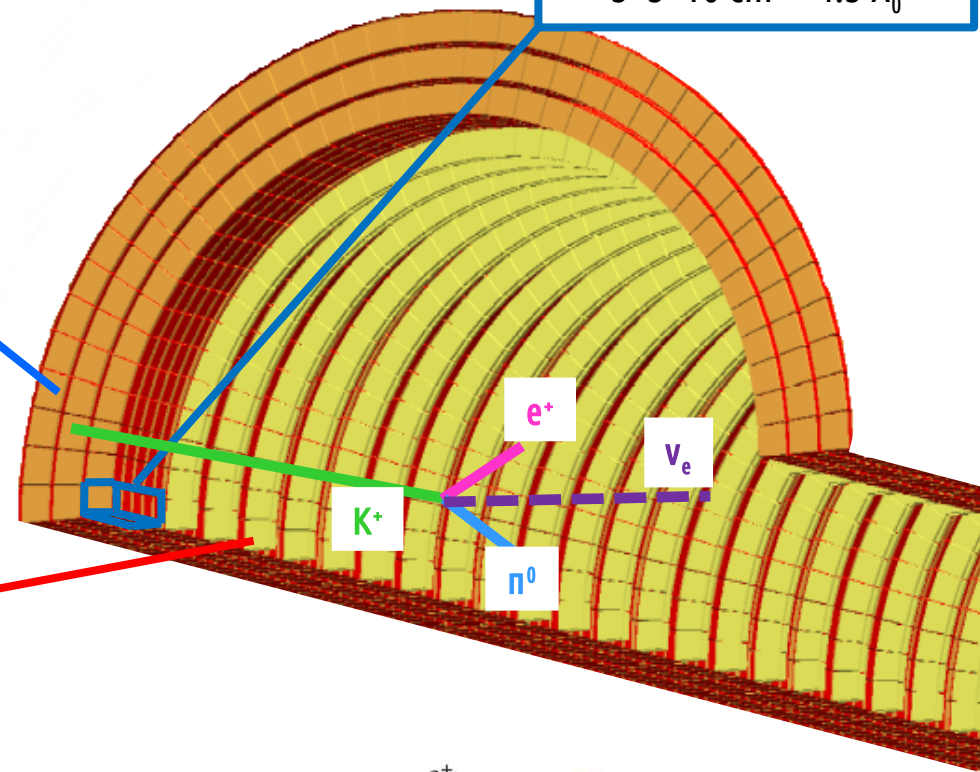
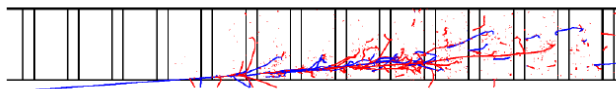

Integrated photon veto

Plastic scintillators
 Rings of $3 \times 3 \text{ cm}^2$ pads

→ n^0 rejection

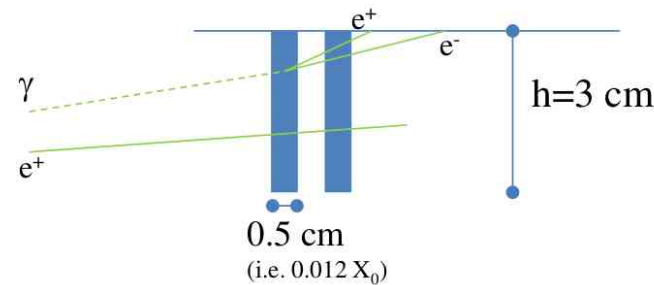
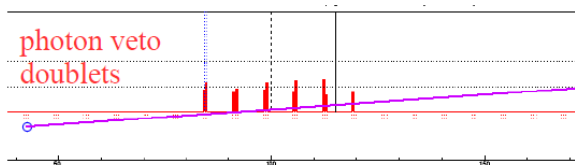

e^+ (signal) topology



π^0 (background) topology



π^+ (background) topology

The tagger: shashlik with integrated readout

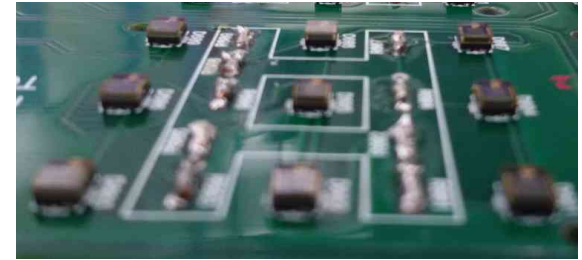
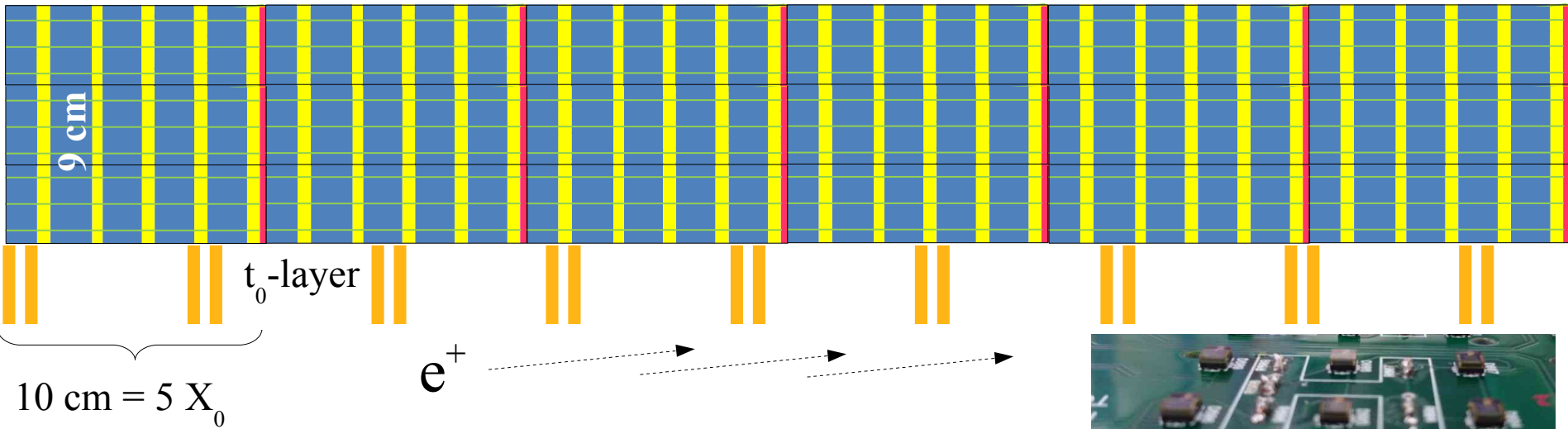

CERN PS test beam Nov 2016

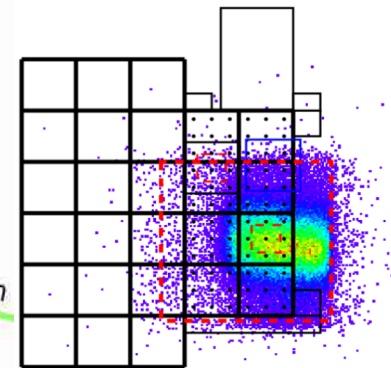
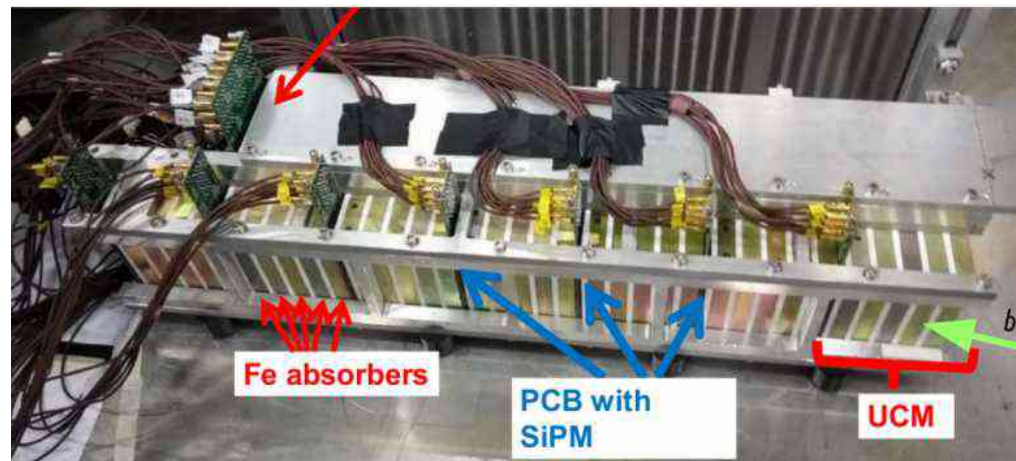
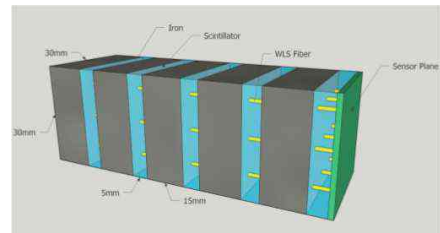

Test beam results with shashlik readout



Calorimeter prototype performance with test-beam data @ CERN-PS T9 line 2016-2017

Tested response to MIP, e and π^-

- e.m. energy resolution: $17\%/\sqrt{E}$ (GeV)
- Linearity deviations: $<3\%$ in 1-5 GeV range
- From 0 to 200 mrad \rightarrow no significant differences
- Work to be done on the fiber-to-SiPM mechanical coupling \rightarrow dominates the non-uniformities
- Equalizing UCM response with mips MC/data already in good agreement
- longitudinal profiles of partially contained π reproduced by MC @ 10% precision

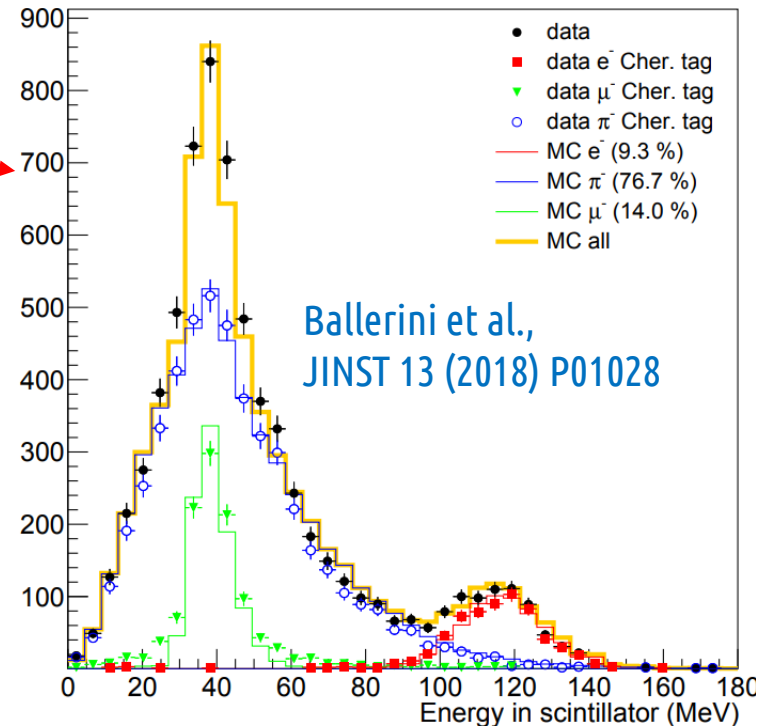
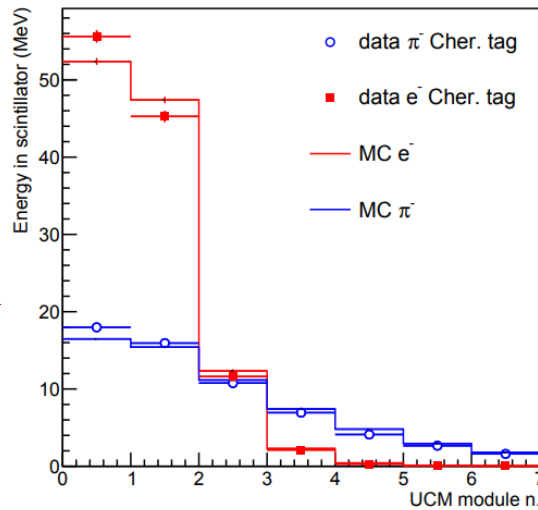
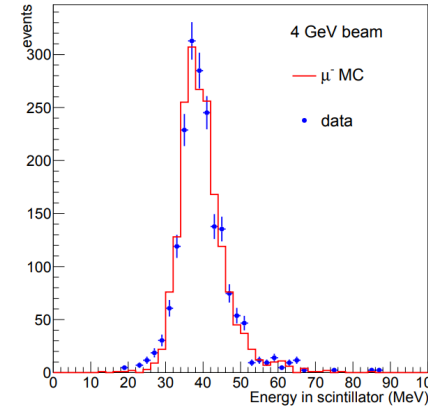
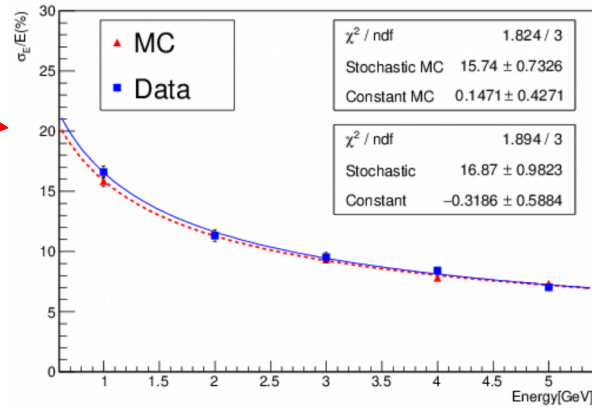

SiPM irradiation studies

SiPM were irradiated at LNL-INFN with 1-3 MeV neutrons in Jun 2017

→ Characterization of 12,15 and 20 μm SiPM cells up to $1.2 \times 10^{11} \text{ n/cm}^2$
 1 MeV-eq (max non ionizing dose for $10^4 v_e^{CC}$ at a 500 t v detector)

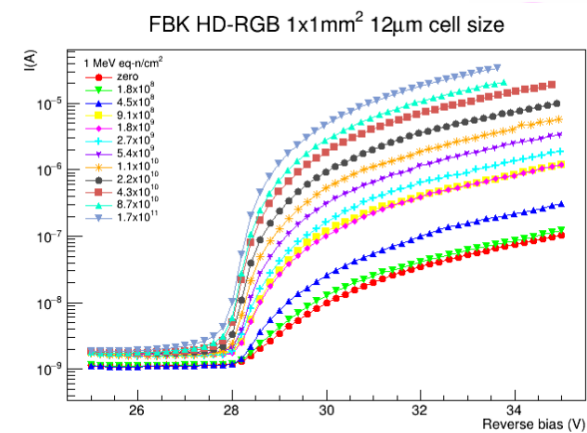

Expected neutron doses (FLUKA)

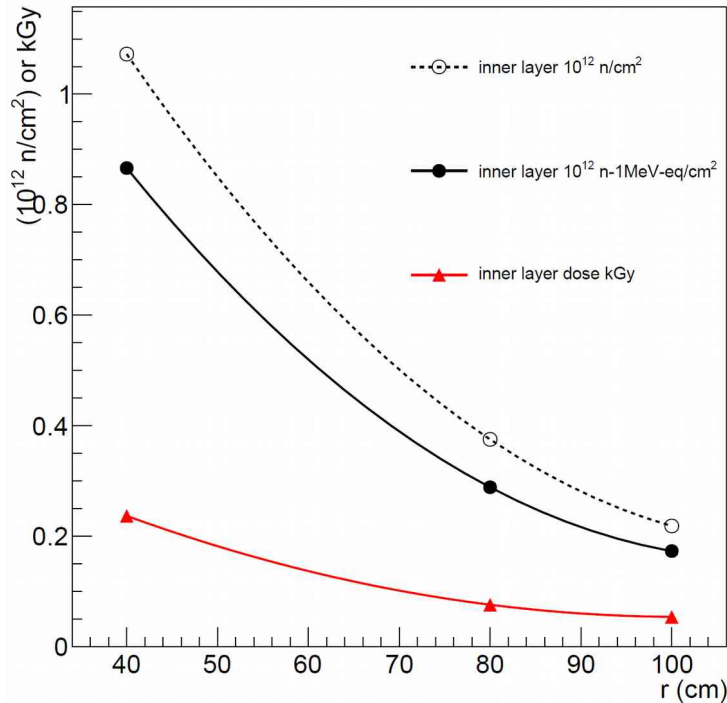

Irradiated SiPM tested at CERN in Oct 2017

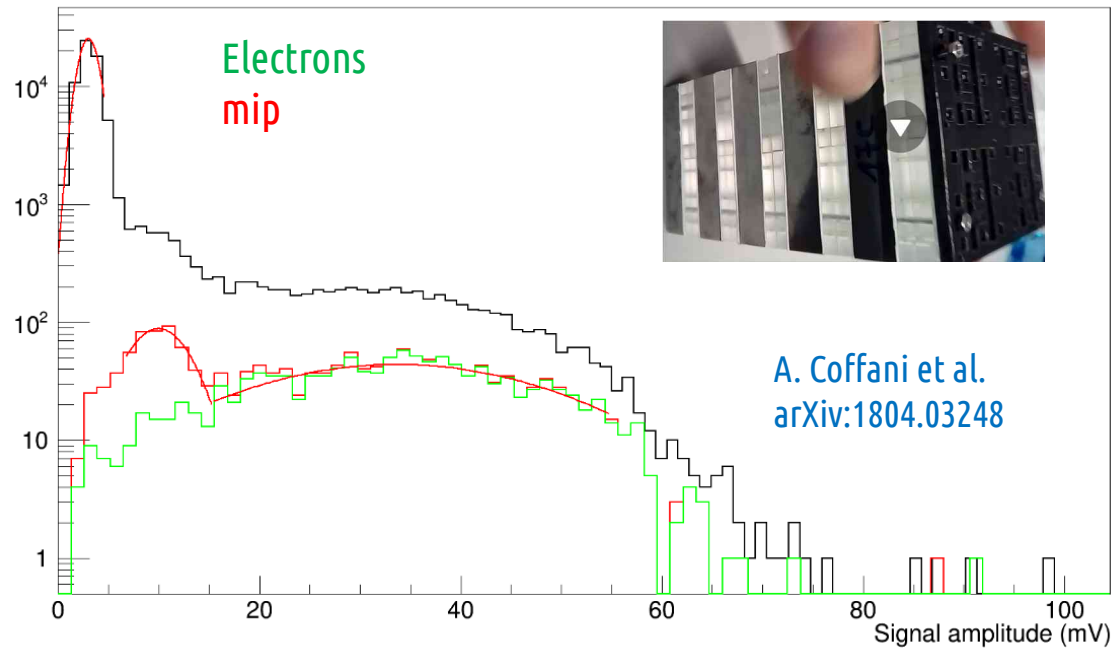

- Mips can be used from **channel-to-channel intercalibration** even after the maximal irradiation.
- Tests allowed **tuning of scintillator thickness** (or equivalently min p.e. yields) and **compensation with overvoltage tuning**.

The tagger: lateral readout option

Light collected from scintillator sides and **bundled** to a single SiPM reading 10 fibers (1 UCM). SiPM are not immersed anymore in the hadronic shower → less compact but .. much **reduced neutron damage** (larger safety margins), better **accessibility**, safer **WLS-SiPM coupling**.

Sampling calorimeter with lateral WLS light collection

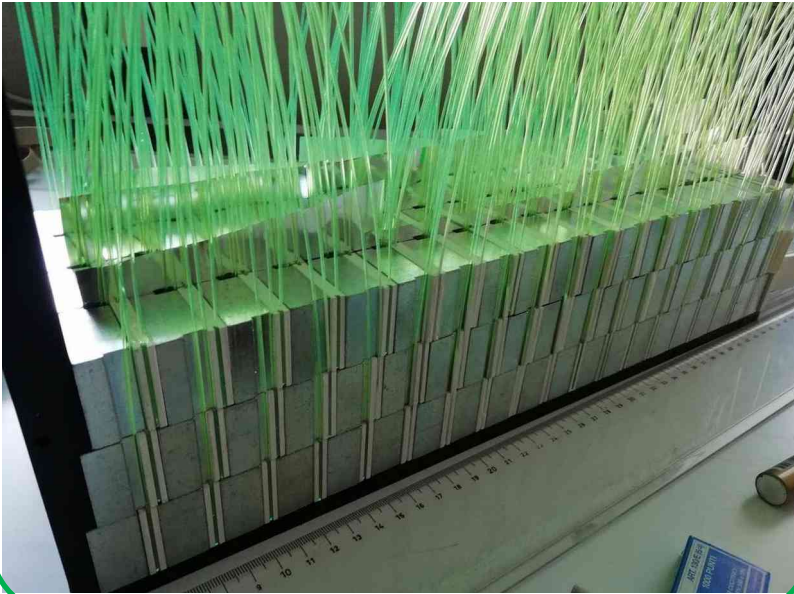

May 2018, CERN-PS test beam

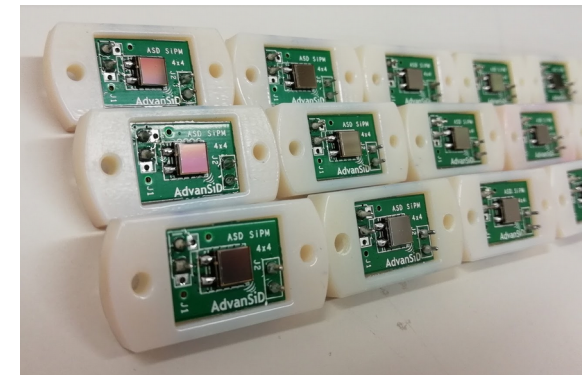
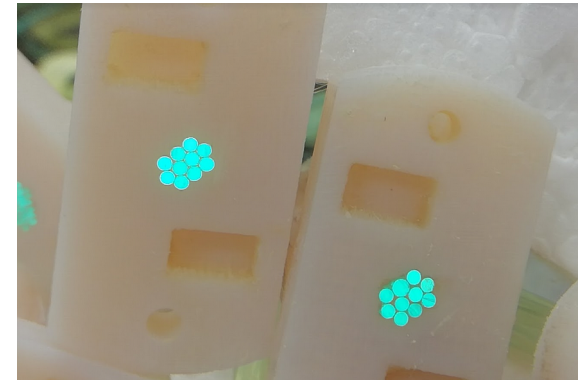
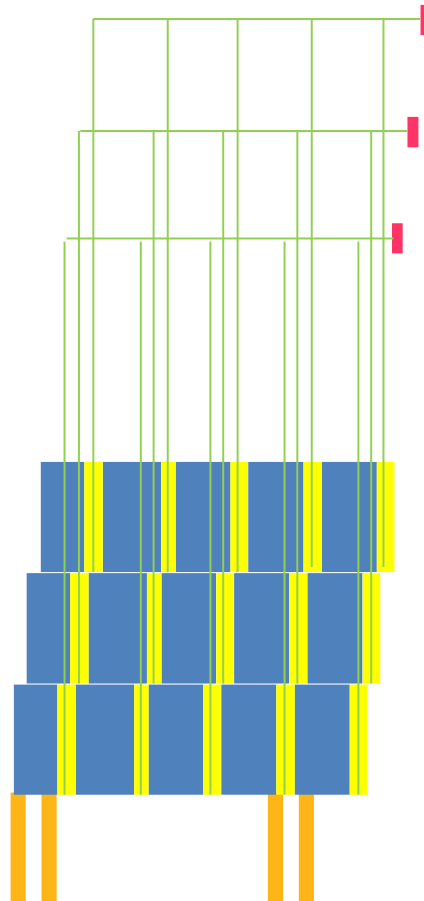

The Tagger – Detector R&D

September 2018 CERN-PS: a module with hadronic cal. for pion containment and **integrated t_0 -layer**

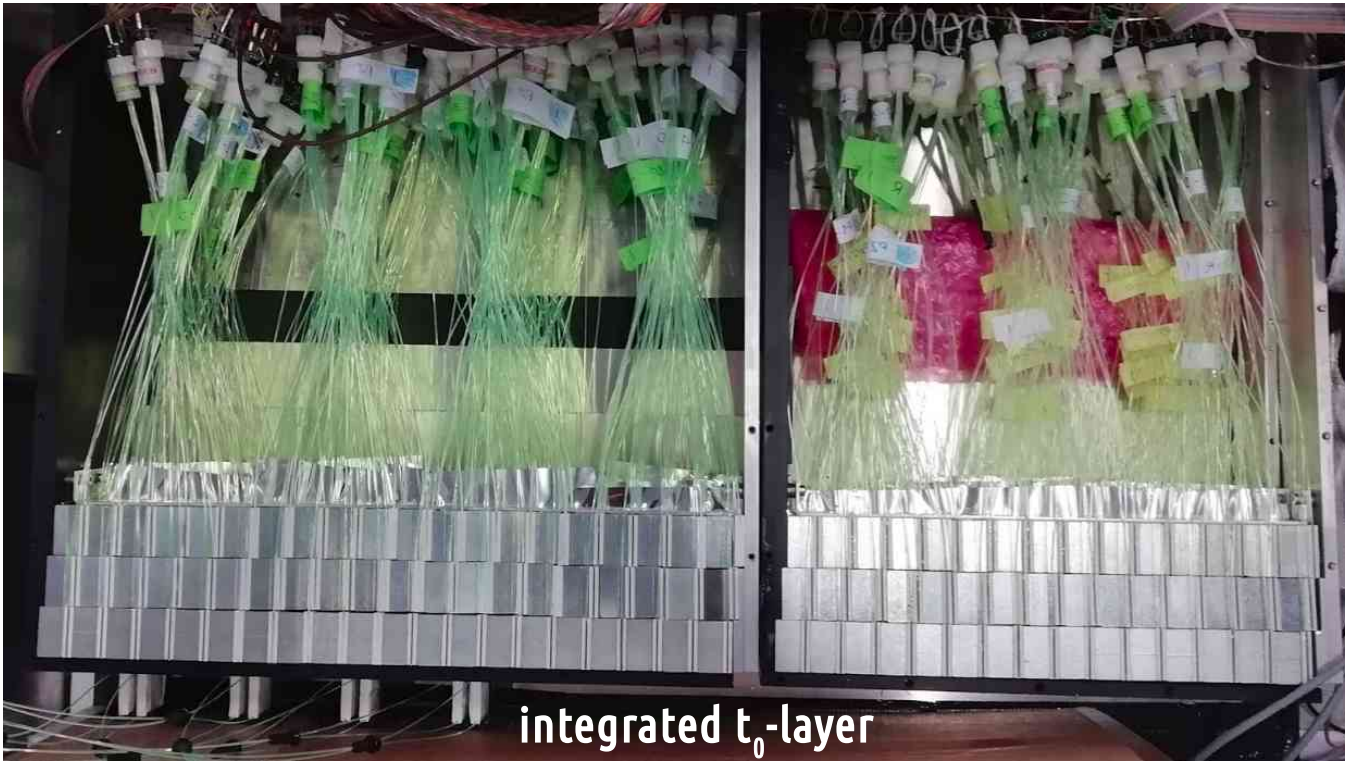

Resolution, light yield, uniformity, optical coupling to photo-sensors, e/π separation. In progress.

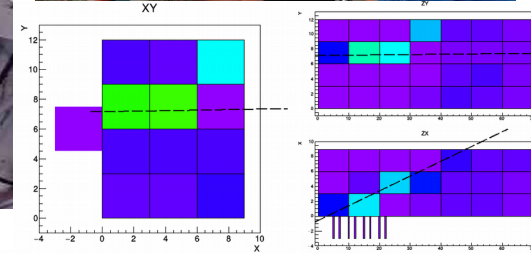

Efficiency maps

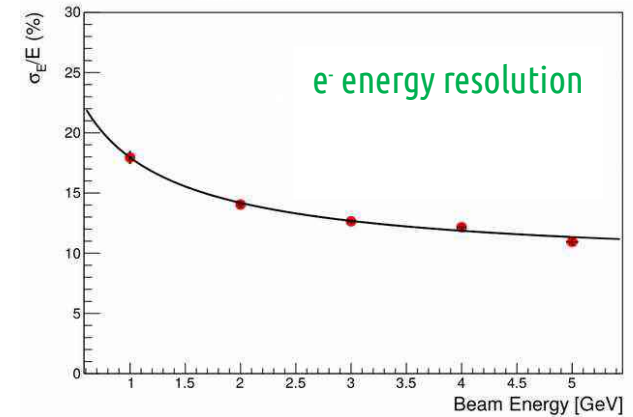
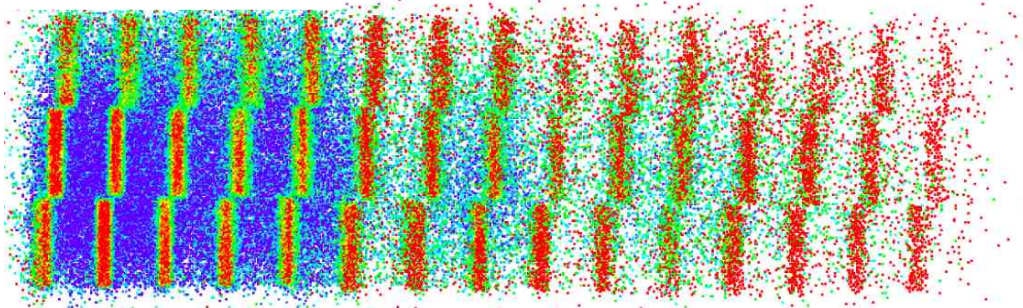

The photon veto - test beam

@ CERN-PS T9 line 2016-2018

- γ / e^+ discrimination + timing
- scintillator ($3 \times 3 \times 0.5 \text{ cm}^3$) + WLS Fiber + SiPM
- light collection efficiency $\rightarrow >95\%$
- time resolution $\rightarrow \sigma \sim 400\text{ps}$
- 1 mip/2 mip separation

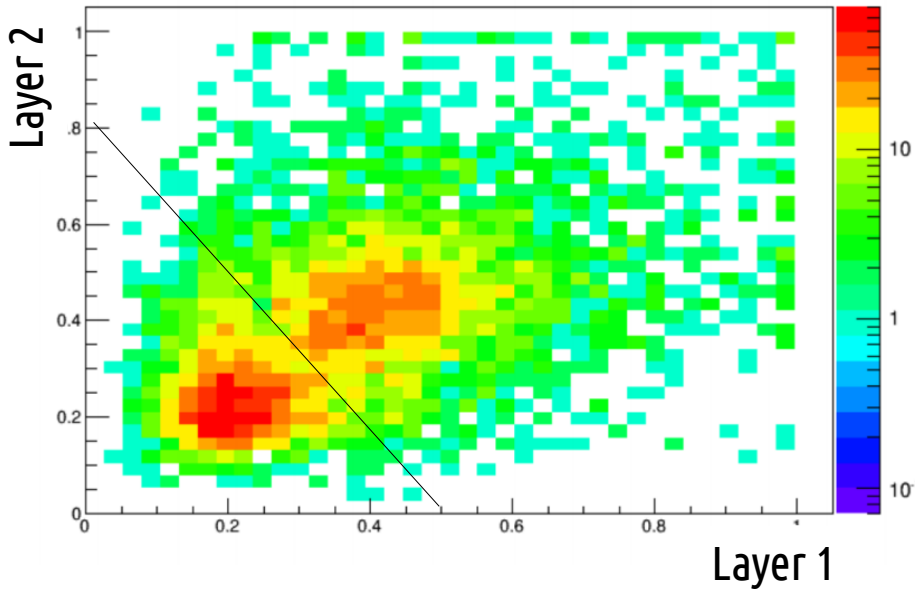
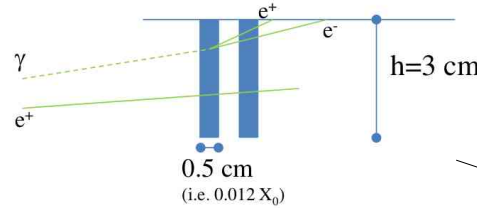

charge exchange: $\pi^- p \rightarrow n \pi^0 (\rightarrow \gamma\gamma)$
 Trigger: PM1 + VETO + PM2

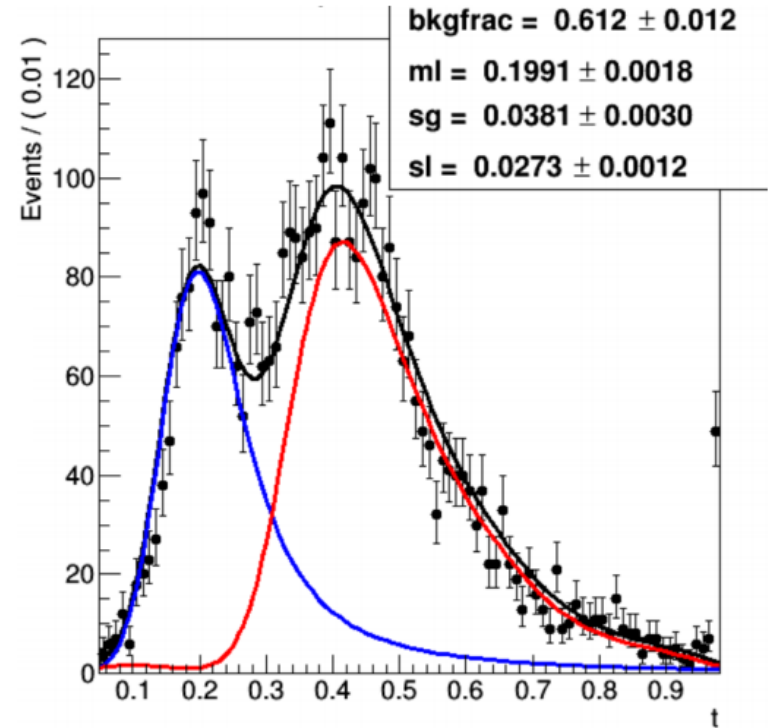
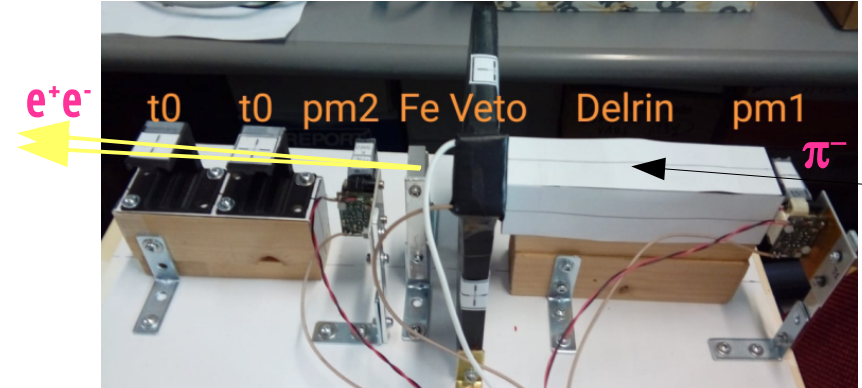

Particle rates in the tunnel

Static focusing system
 4.5×10^{13} pot in 2 s (400 GeV)

Calorimeter 1 m from the axis of the tunnel ($R_{\text{inner}}=1.00$ m)
Three radial layers of UCM ($R_{\text{outer}}=1.09$ m)

Rate vs longitudinal position in the tunnel

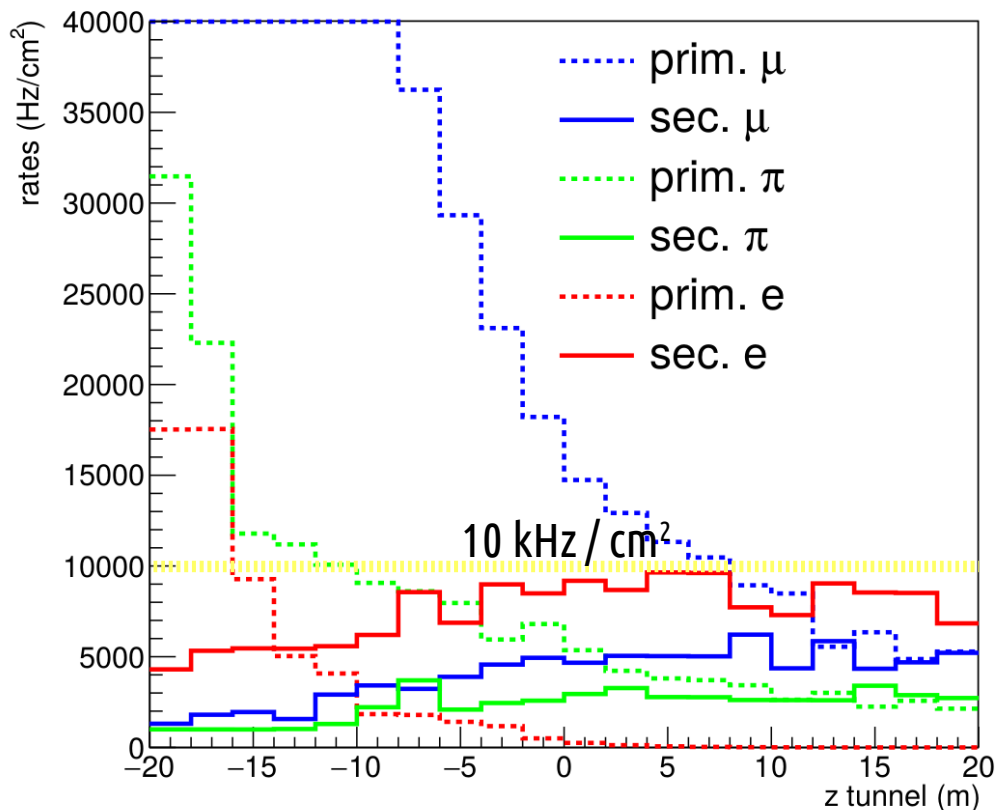

Rate vs the azimuthal angle in the tunnel

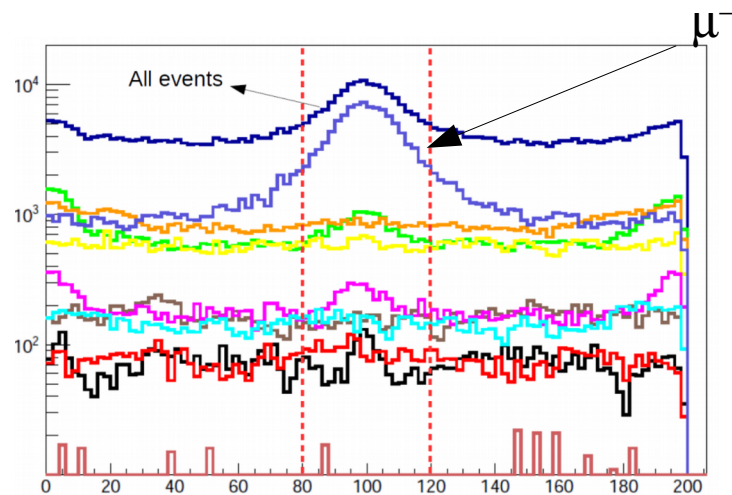

The bulk of the muons lies on the dipole Bending plane \rightarrow can be easily removed

Positron ID from K decay

Full **GEANT4 simulation** of the detector, **validated** by prototype tests at CERN in 2016-2018. Includes particle propagation and decay, from the transfer line to the detector, hit-level detector response, pile-up effects.

Analysis chain

F. Pupilli et al., PoS NEUTEL2017 (2018) 078

- Event Builder** → Identify the seed of the event (UCM with large energy deposit) and cluster neighboring modules (in time and space)
- $e/\pi/\mu$ separation** → Multivariate analysis based on 6 variables (pattern of the energy deposition in the calorimeter) with TMVA
- e/γ separation** → Signal on the tiles of the photon veto

Purity x Efficiency ($Ke_3 e^+$)

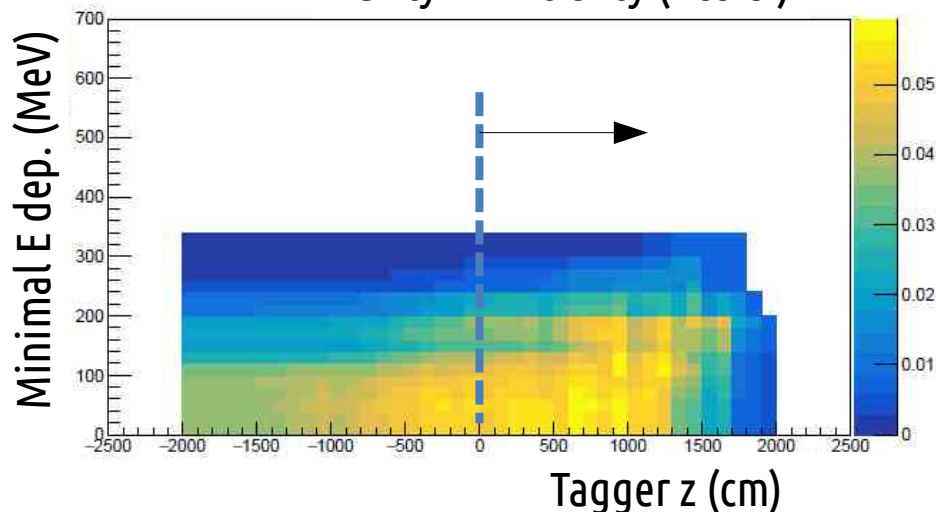

ϵ_{geom}	0.36
ϵ_{sel}	0.55
ϵ_{tot}	0.20
Purity	0.26
S/N	0.36

ϕ cut → **0.46**

Instrumenting half of the decay tunnel:
 $Ke_3 e^+$ at single particle level with a $S/N = 0.46$

Neutrino events per year at the detector

- **Detector mass:** 500 t (e.g. **Protodune-SP** or **DP @ CERN**, **ICARUS @ Fermilab**)
- **Baseline** (i.e. distance between the detector and the beam dump) : 50 m
- **4.5×10^{19} pot at SPS** (0.5 / 1 y in dedicated/shared mode) or **1.5×10^{20} pot at FNAL**

ENUBET @ SPS, 400 GeV, 4.5e19 pot, 500 ton detector

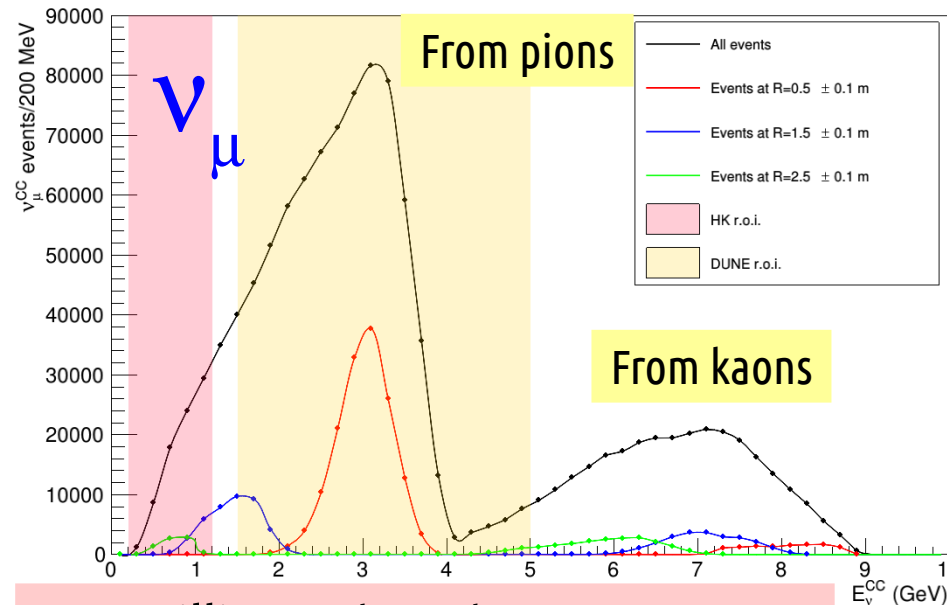

1.2 million ν_μ Charged Current per year

ENUBET @ SPS, 400 GeV, 4.5e19 pot, 500 ton detector

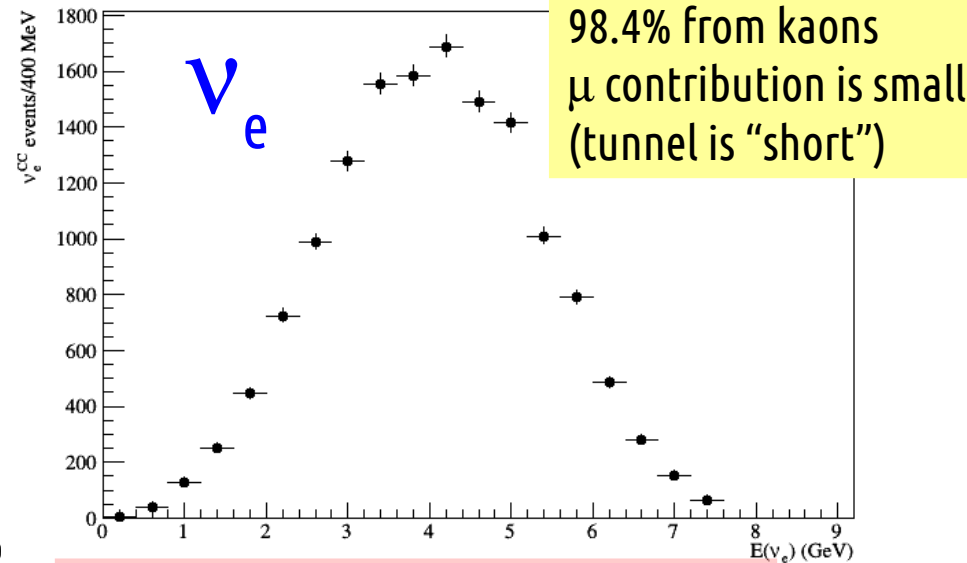

14000 ν_e Charged Current per year

- ν_μ from K and π are **well separated** in energy (narrow band)
- ν_e and ν_μ from K are constrained by the tagger measurement (K_{e3} , mainly $K_{\mu 2}$).
- ν_μ from π : μ detectors downstream of the hadron dump (under study)

ν_μ CC events at the ENUBET narrow band beam

The neutrino energy is a function of the distance of the neutrino vertex from the beam axis.

ENUBET @ SPS, 400 GeV, 4.5e19 pot, 500 ton detector

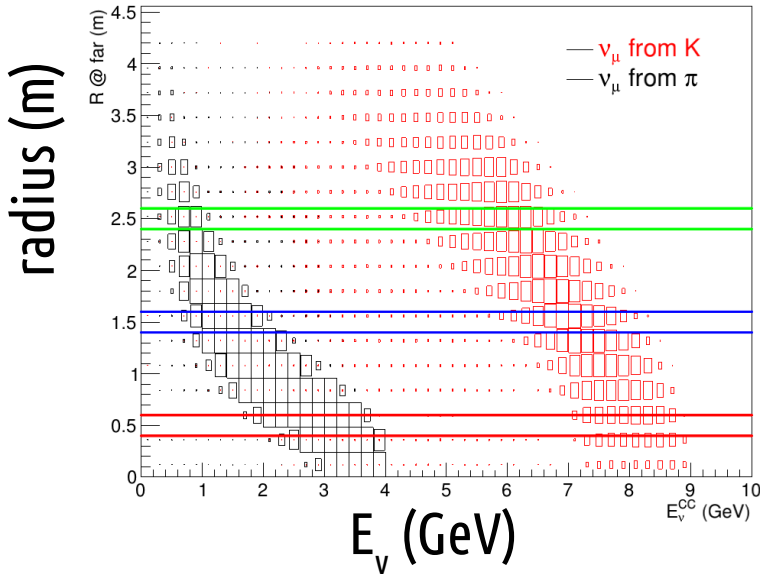

ν_μ^{CC} in radial bins (1 norm.)

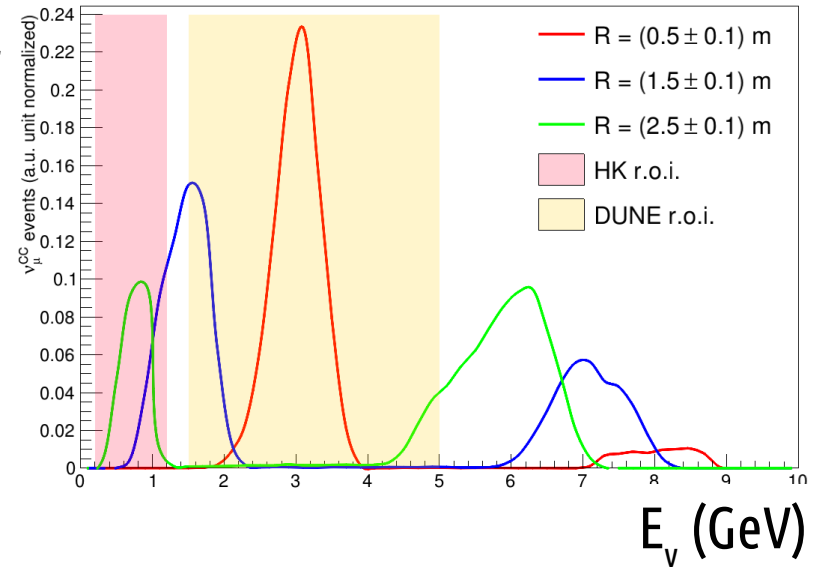

The beam width at fixed R (\equiv neutrino energy resolution) for the pion component is

- 8 % for $r \sim 30$ cm, $\langle E_\nu \rangle \sim 3$ GeV
- 22% for $r \sim 250$ cm, $\langle E_\nu \rangle \sim 0.7$ GeV

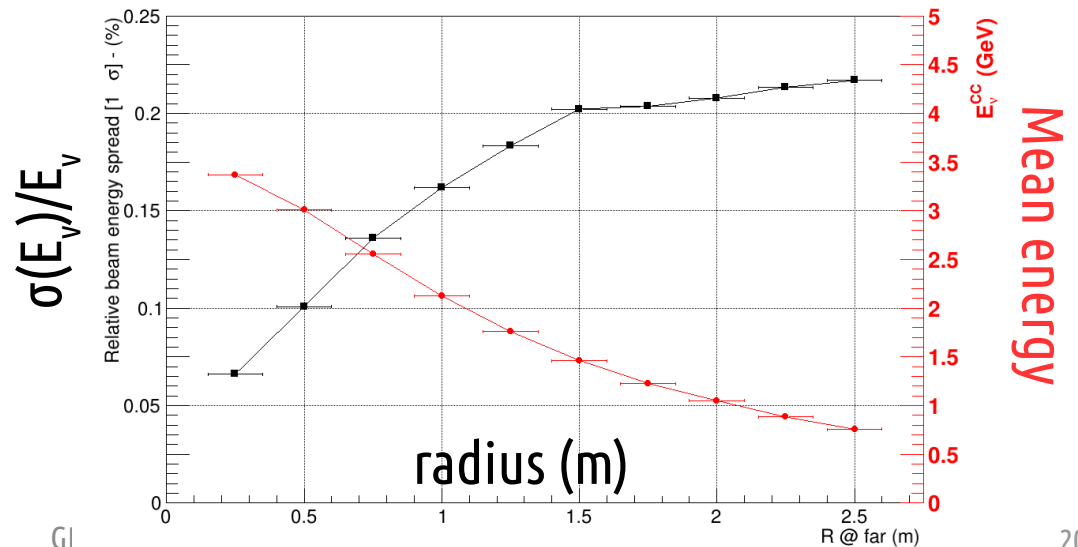

ν_μ CC events at the ENUBET narrow band beam

The neutrino energy is a function of the distance of the neutrino vertex from the beam axis.

ENUBET @ SPS, 400 GeV, 4.5e19 pot, 500 ton detector

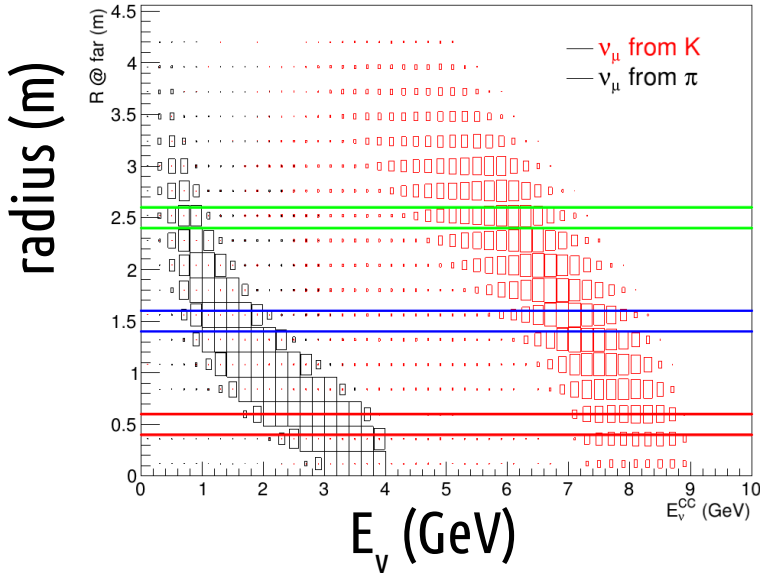

ν_μ CC in radial bins (1 norm.)

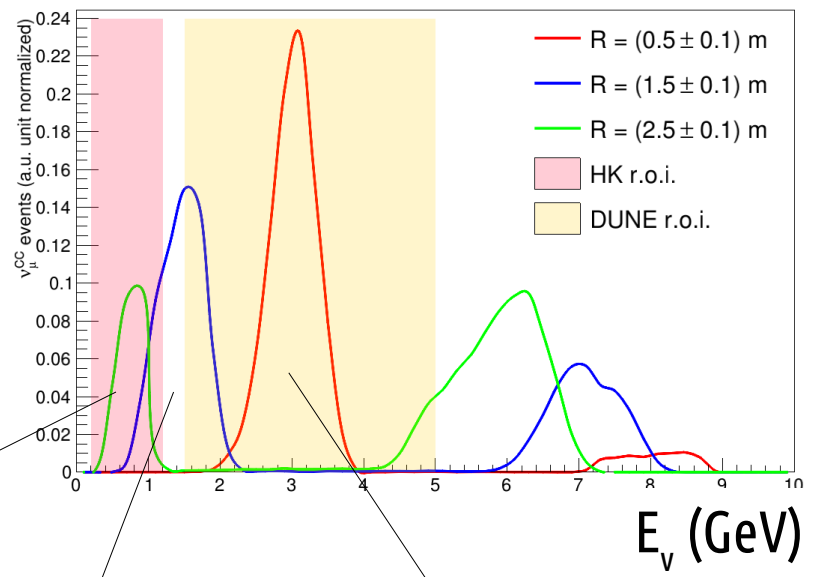

Momentum of $\nu_\mu^{CC} \mu^-$ on Ar.

GiBUU generator (Gauss flux approx.)

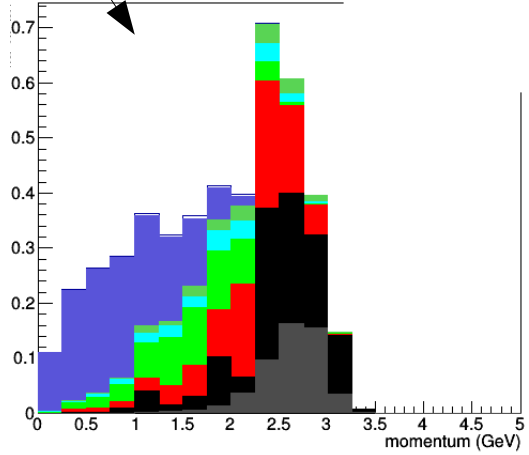
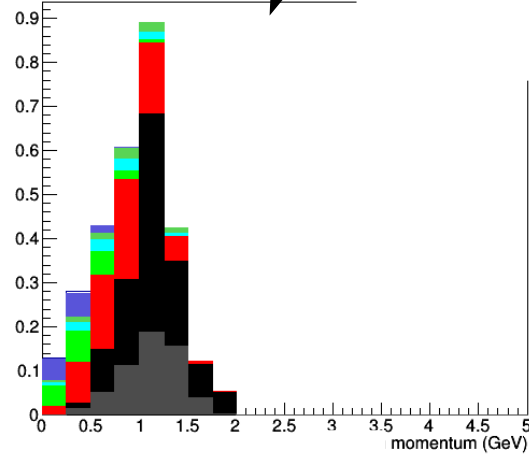
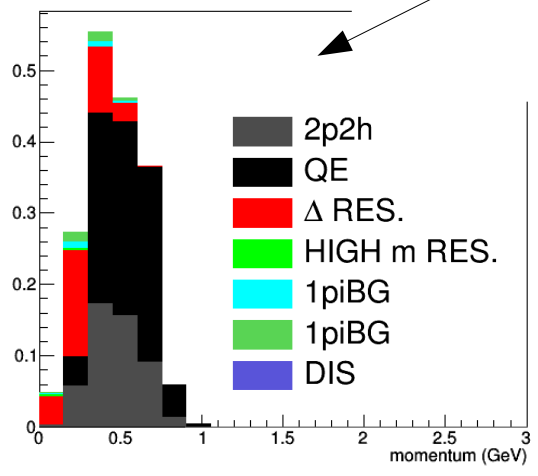

Conclusions

ENUBET is a **narrow band beam** with a high **precision monitoring** of the flux at source ($O(1\%)$) and control of the E_ν spectrum (20% at 1 GeV \rightarrow 8% at 3 GeV)

2018 has been a special year, we have

- provided the first **end-to-end simulation of the beamline** (Jul)
- Proved the feasibility of a **purely static focusing system** ($10^6 \nu_\mu^{CC}$, $10^4 \nu_e^{CC}$ /y/500 t)
- **full simulation of e^+ reconstruction**: single particle level monitoring. $S/N \sim 0.5$
- Tested with machine data the **“burst” slow extraction** scheme at the CERN-SPS (Aug)
- **completed the test beams** campaign (Sep) before LS2
 - \rightarrow identified best options for instrumentation (**shashlik** and **lateral** readout)
- Strengthened the **physics case**:
 - \rightarrow slow extraction + **“narrow band off-axis technique”**

The ENUBET technique is **very promising** and the results we got in the last twelve months exceeded our expectations

Next steps



- In **2019** we need to:
 - **decide on the light readout technology** for the final demonstrator (shashlik versus “lateral readout”)
 - **improve the design of the beamline** to reduce beam halo contamination (current e^+ S/N can be significantly improved)
 - re-optimize the **tunnel radius** to increase geometrical acceptance

- **Systematic assessment on predicted neutrino fluxes**
- Develop new ideas to **enhance precision also on ν_μ**
 - from $K_{\mu 2}$ with μ id in the tagger
 - from π : counting μ from π in hadron-dump (could be feasible with a 2s extraction).
- **CDR at the end of the project (2021): physics and costing**
- Build a **demonstrator prototype** of the tagger (2021)



Padova June 2016



CERN Nov 2016

CERN Aug 2017



CERN Oct 2017

INFN-LNL Jun 2017

THANKS!



CERN May 2018

CERN Sep 2018



Milan Oct 2017



A. Longhin - ENUBET

GDR neutrino - 6/11/2018

ENUBET in the European strategy



The ENUBET mission is to demonstrate the **feasibility** of the tagged neutrino beam approach at CERN, J-PARC or FNAL (**site independent**).

Still... the protoDUNE prototypes would be **ideal** detectors for a future experiment: right **mass**, **timeliness**, redundancy from **dual baseline**, appropriate logistics, an opportunity for a **coherent development of the original physics program** (**reduction of syst. for DUNE-HyperK**).

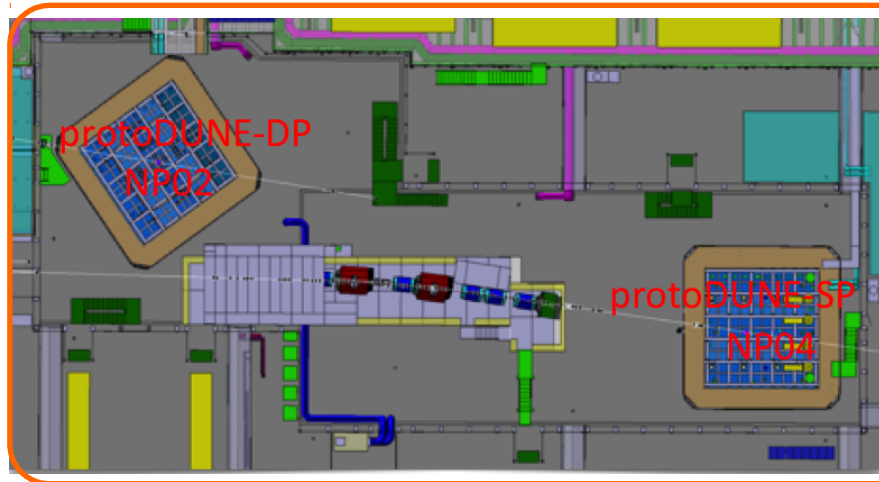

~ to scale
(simply a sketch)

ENUBET

beamline

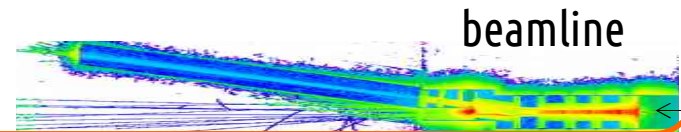

tagger

The ENUBET beamline: “static” option

- Proton extraction scheme: **Single slow extraction (2-4 s)**.
- Reference beam: 8.5 GeV/c, 10% momentum bite
- Quadrupoles: 15 cm wide, $L < 2$ m, $B = 4$ to 7 T/m
- Dipole: 15 cm wide, $L = 2$ m, $B = 1.8$ T \rightarrow **7.4° bending**
- Envelope at tunnel exit 50×50 cm (Tunnel radius 1 m)

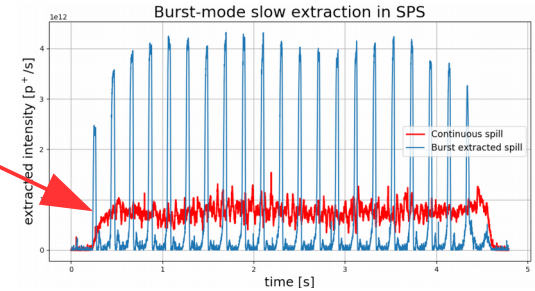

Optics optimized through **TRANSPORT**

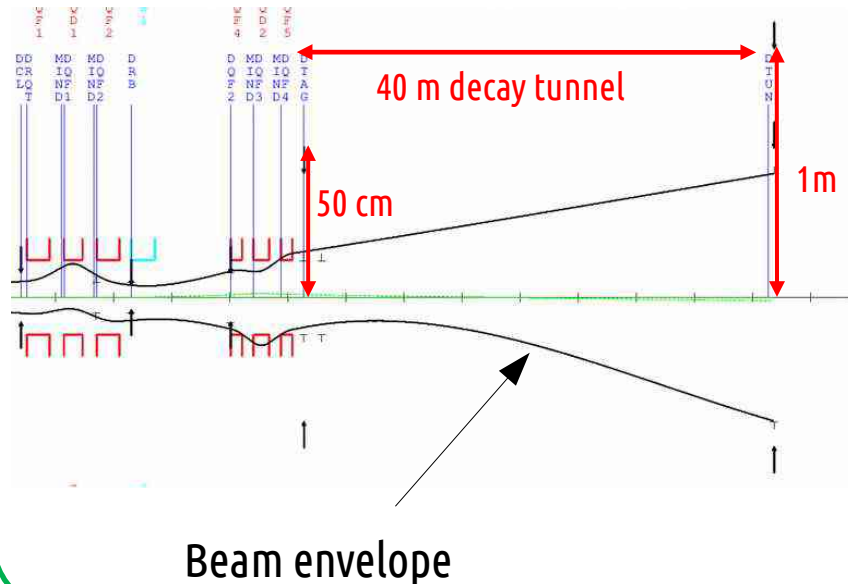

G4beamline

“full simulation” \rightarrow efficiencies, backgrounds

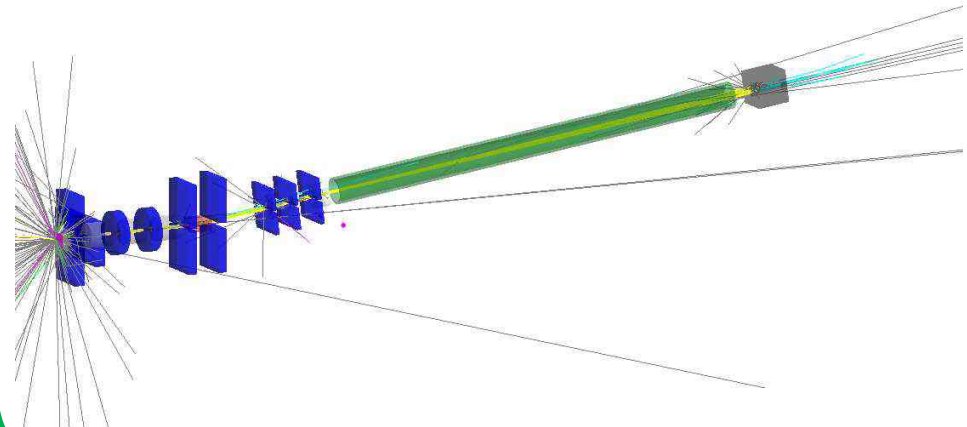

The static beamline: FLUKA simulation

Assess the specs of rad-hard upstream focusing quadrupoles

Optimize shielding to

- **reduce halos** in the tagger region
- **suppress the decays** of off-momentum mesons **out of tagger acceptance**

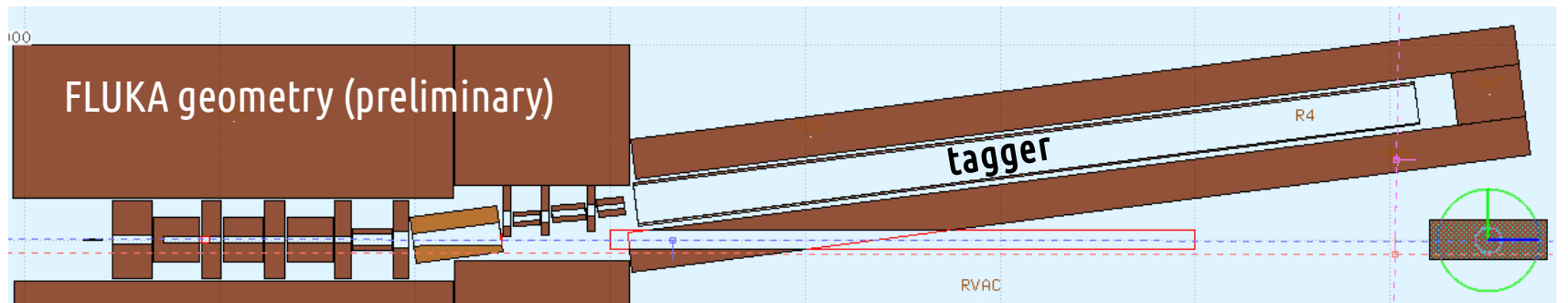

E deposition. 400 GeV/c p on target

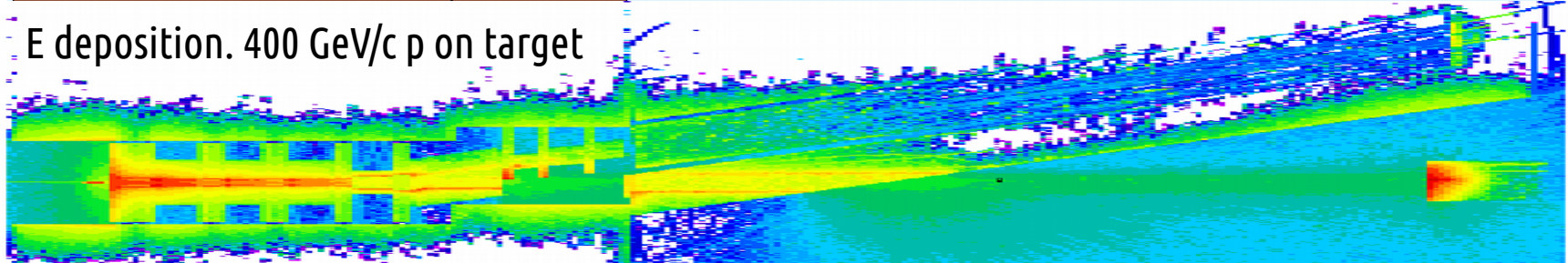

8.5 GeV/c parallel π^+

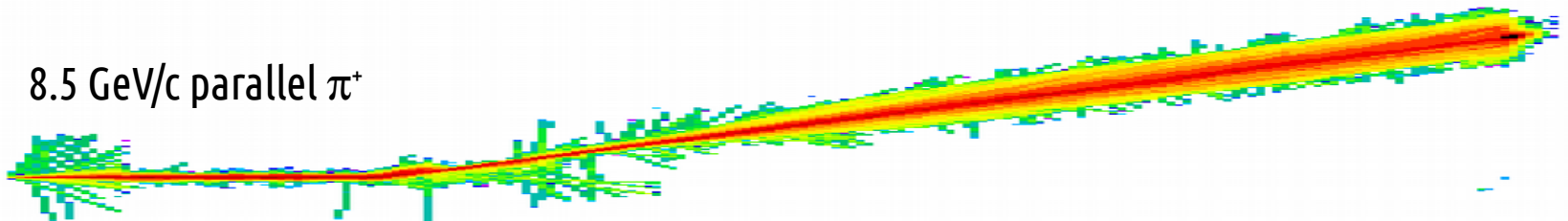

The ENUBET monitored beam



- **Hadron beam-line**: charge selection, focusing, fast transfer of π^+/K^+
- **Tagger**: real-time, "inclusive" monitoring of K decay products

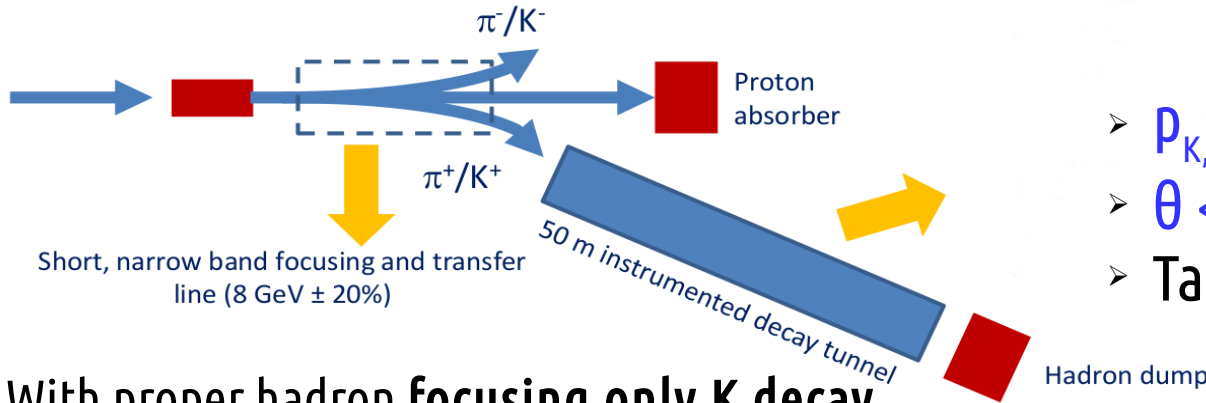

- $p_{K,\pi} = 8.5 \pm 20\% \text{ GeV}/c$
- $\theta < 3 \text{ mrad}$ over $10 \times 10 \text{ cm}^2$
- Tagger: $L = 50 \text{ m}$, $r = 40 \text{ cm}$

- ✓ With proper hadron **focusing only K decay products** are measured in the tagger being emitted at **large angles** (unlike pion decay products) allowing
 - ✓ a **complete control** of produced ν_e using e^+ from K_{e3} ($\sim 98\%$). Muon decays gives a small contribution thanks to the short tunnel ($\sim 50 \text{ m}$).
 - ✓ **tolerable rates / detector irradiation**
 $< 500 \text{ kHz}/\text{cm}^2$, $O(\sim 1 \text{ kGy})$

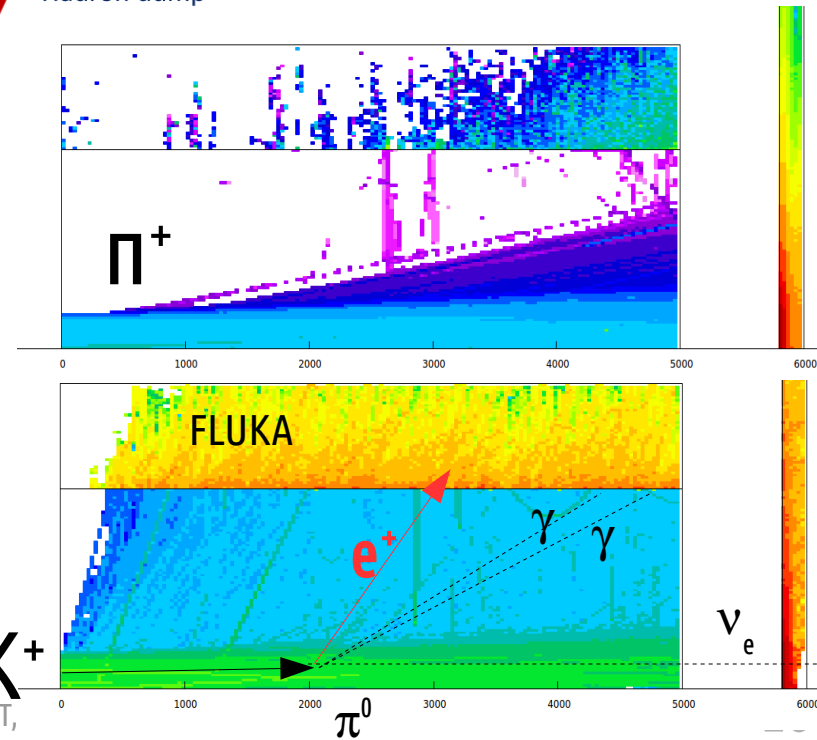

The Tagger – positron ID from K decay

Event Builder



Seed of the event = UCM in first layer with energy deposit > 20 MeV \square link neighboring modules with time (1ns) and position requirements

e/n separation

Neural network

TMVA multivariate analysis based on 5(+6) variables (pattern of the energy deposition in the calorimeter)

Response to signal and background

TMVA overtraining check for classifier: MLPBNN

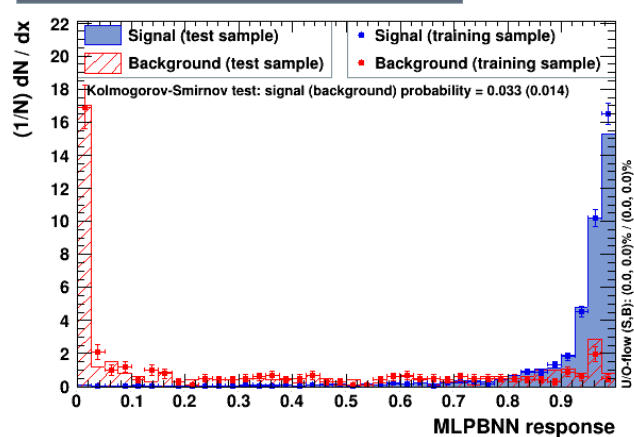

Cut efficiencies and optimal cut value

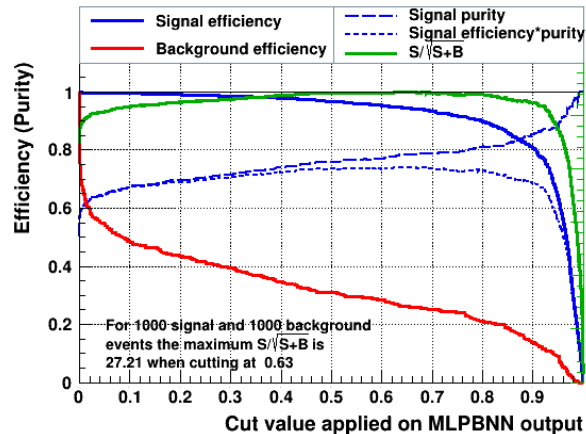

Background rejection versus Signal efficiency

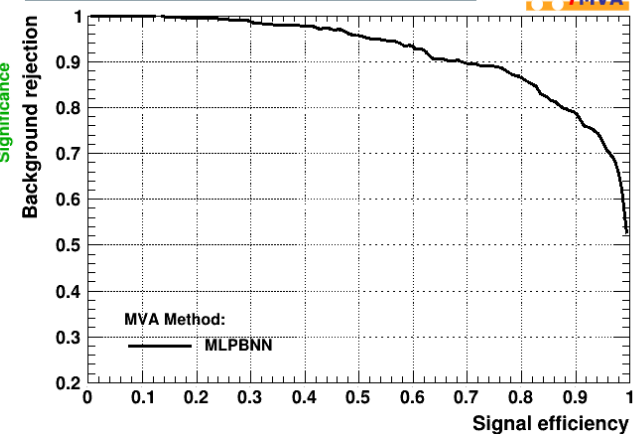

e/y separation



n^0 rejection: we require 3 layers of t_0 before first calorimeter energy deposit compatible with a mip (0.65-1.7 MeV)