

NuFact 2021: The 22<sup>nd</sup> International Workshop  
on Neutrinos from Accelerators

9<sup>th</sup> September 2021

---

# **Detector R&D for the ENUBET instrumented decay region**

---

Fabio Iacob  
on behalf of the ENUBET collaboration

Università degli Studi di Padova  
INFN, Sezione di Padova

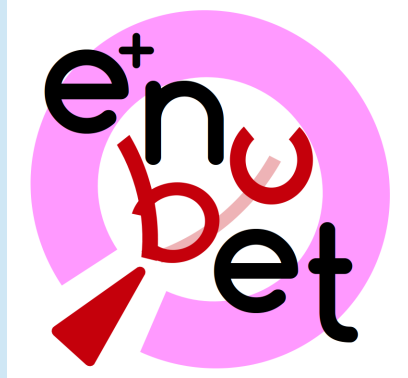

This project has received funding from the European Research Council (ERC) under the European Union's Horizon 2020 research and innovation programme (grant agreement N. 681647)

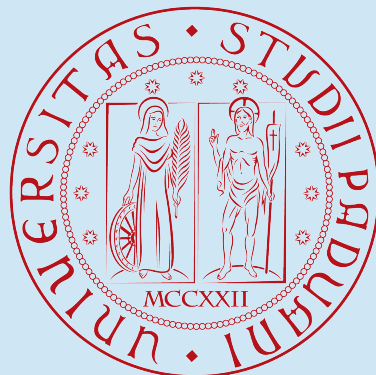

---

# Physics goal and strategy

---

1. Physics goal and strategy
2. Lateral readout calorimeter
3. Demonstrator
4. Conclusions

# ENUBET/NP06 intro

**ENUBET:** Enhanced NeUtrino BEams from Kaon Tagging

- The ENUBET ERC project started in June 2016 and will last until June 2022.
- Its main hardware output will be a portion of a newly conceived instrumented decay tunnel: the “demonstrator”.

**NP06:** CERN Neutrino Platform experiment number 6

- ENUBET was approved to be a CERN Neutrino Platform experiment in March 2019.
- The demonstrator will be exposed to particle beams at the Proton Synchrotron (PS), CERN.

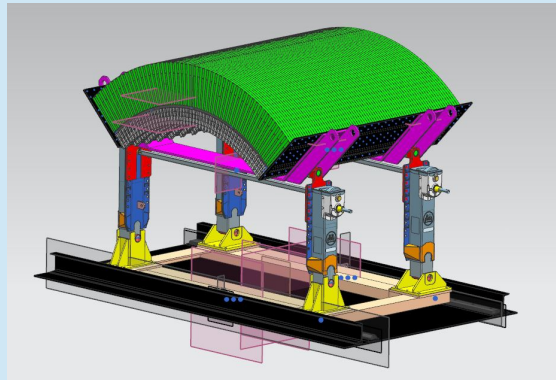

*The demonstrator*

# Goal and motivation

## ENUBET/NP06 GOAL

The ENUBET/NP06 goal is to reduce the uncertainty of  $\nu_e$  and  $\nu_\mu$  fluxes in neutrino beam experiments below the 1% threshold.

## MOTIVATION

$\nu_e$  and  $\nu_\mu$  cross section measurements will benefit from the reduced flux uncertainty, since it constitutes the main systematic source. In the case of ENUBET, the flux uncertainty reduction will enable better cross section analysis in the energies of interest for DUNE and HyperKamiokande.

## EUROPEAN STRATEGY

supported by the European Strategy for Particle Physics Deliberation document (page 5):

*“To extract the most physics from DUNE and Hyper-Kamiokande, a complementary programme of experimentation to determine neutrino cross-sections and fluxes is required. [...]. The possible implementation and impact of a facility to measure neutrino cross-sections at the percent level should continue to be studied.”*

# Design concept

In order to achieve the goal of  $<1\%$   $\nu$ -flux uncertainty ENUBET proposes a beamline with an active decay tunnel and a muon monitor at its end.

- positrons from high-angle kaon decays for  $\nu_e$  are tagged in the decay tunnel.
- muons from high-angle kaon decays for  $\nu_\mu$  and from pion decays are tagged in the decay tunnel and in the muon monitor.
- a time resolution of  $< 200$  ps would permit a particle-by-particle association at the far detector of  $\nu_e$ -CC interactions.

$K^+$ decay mode	Branching ratio (%)
$\mu^+ \nu_\mu$	63.55
$\pi^+ \pi^0$	20.66
$\pi^+ \pi^+ \pi^-$	5.59
$\pi^0 e^+ \nu_e$	5.07
$\pi^0 \mu^+ \nu_\mu$	3.353
$\pi^+ \pi^0 \pi^0$	1.761



Tagged in range-meter

Tagged in decay tunnel

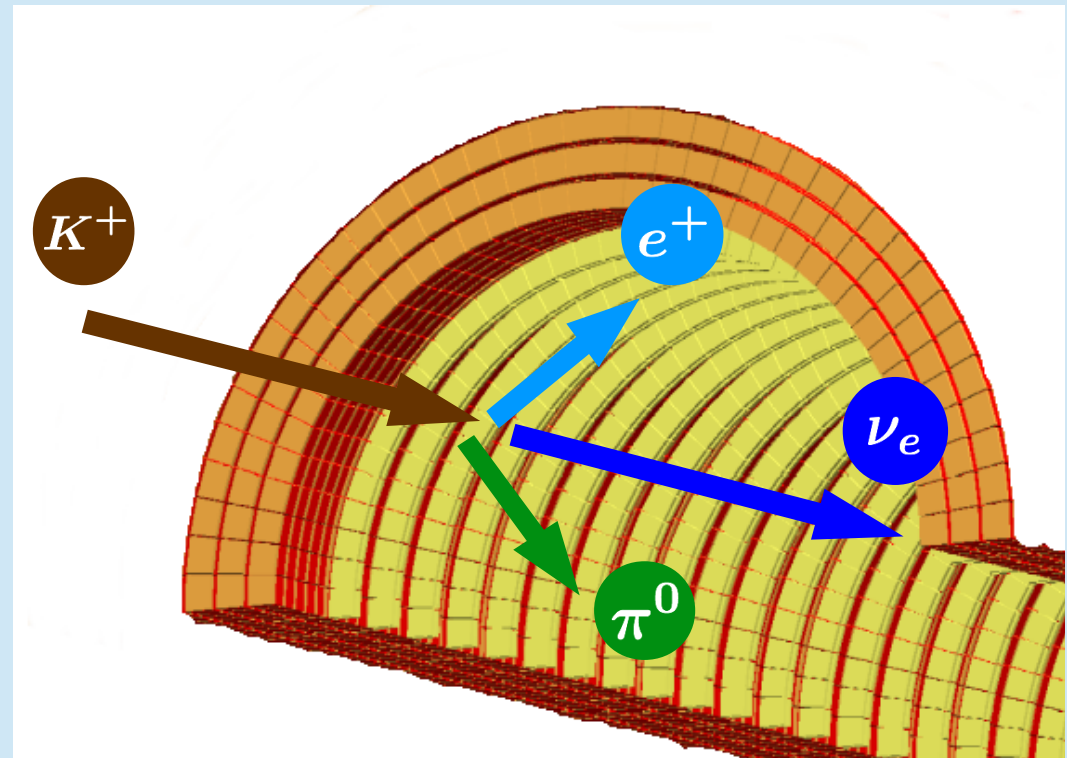

Portion of active decay tunnel

# Design concept

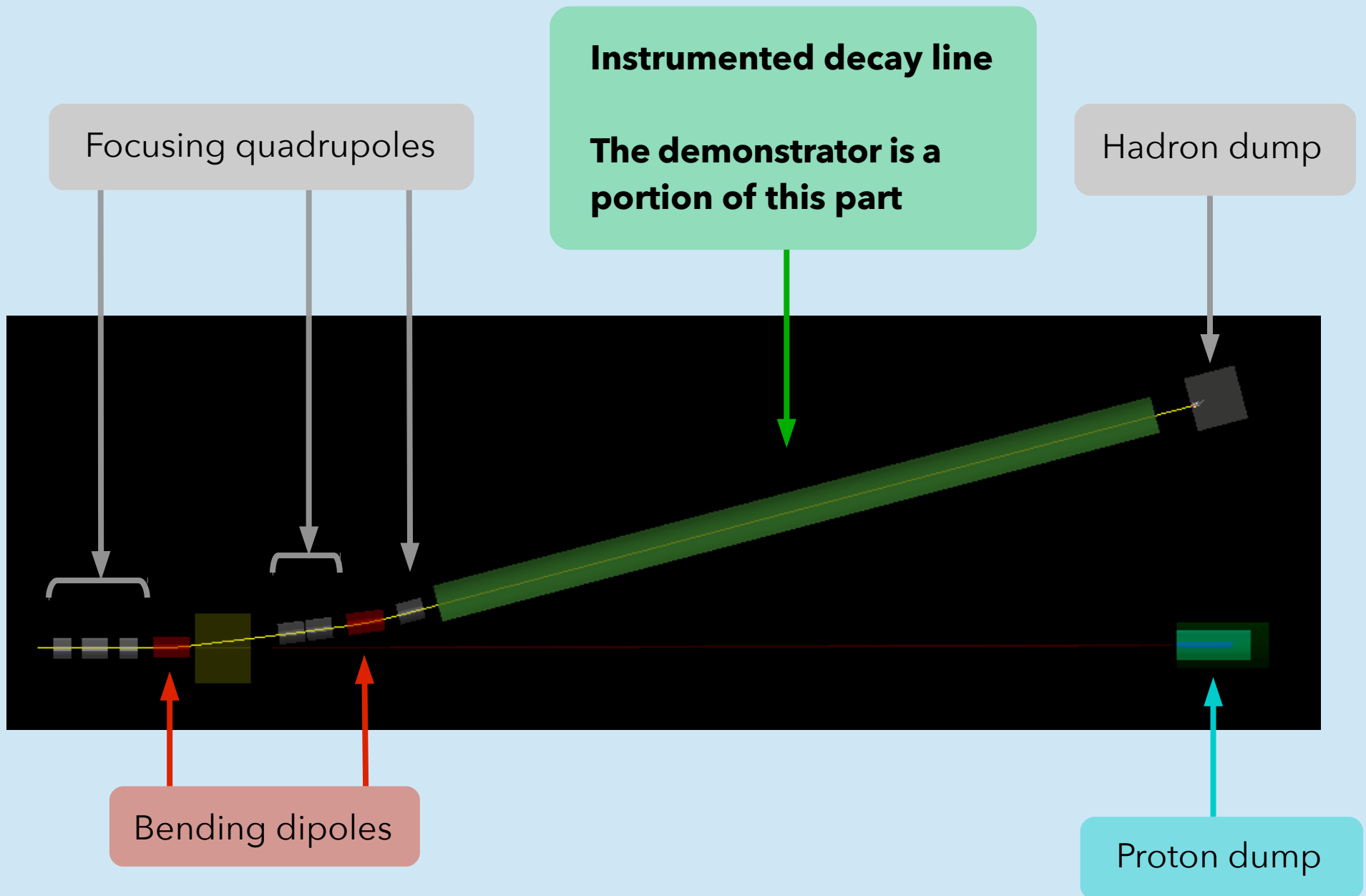

Dedicated talk: "Development and optimization of the ENUBET beamline" (M. Pari)

# Timeline

Start of ERC grant & initial shashlik design beam exposure at CERN-PS

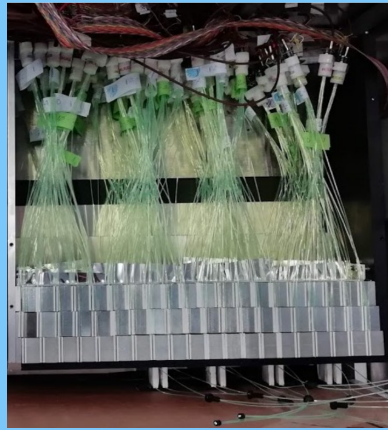

Shashlik to lateral readout design migration for attenuating SiPM radiation damage. Hadronic cal +  $\gamma$ veto prototype beam exposure at CERN-PS

Systematics budget finalization & demonstrator construction

Demonstrator beam exposure at CERN & conceptual design report

1979

2016

2017

2018

2019

2021

2022

*"The possibility of using tagged-neutrino beams in high-energy experiments must have occurred to many people."*  
B. Pontecorvo, Lett. Nuovo Cimento, 25 (1979) 257

SiPM neutron irradiation campaign at INFN-LNL and beam exposure of irradiated sensors at CERN-PS. Result: signal degraded, but inter-calibration spectra still obtainable.

ENUBET becomes a CERN Neutrino Platform experiment



---

# Lateral readout calorimeter

---

1. Physics goal and strategy
2. Lateral readout calorimeter
3. Demonstrator
4. Conclusions

# Lateral compact module

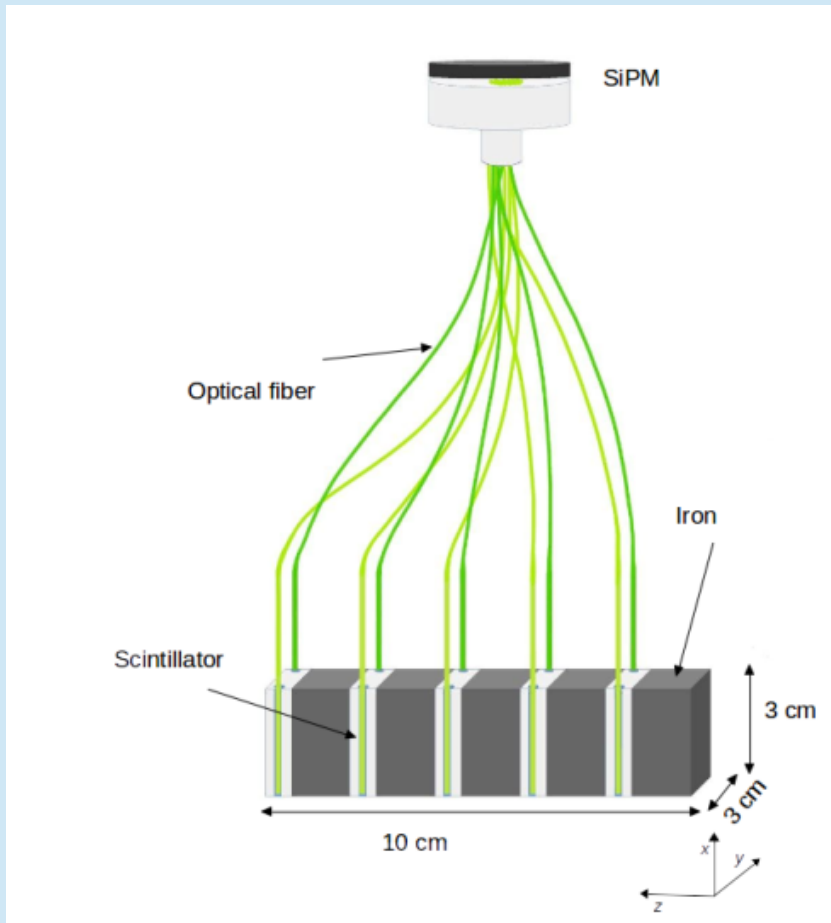

The building block of the lateral readout calorimeter is the Lateral Compact Module (LCM)

- LCM made of 5 steel+scintillator couples
- Each scintillator tile is laterally coupled to 2 optical fibers (so LCM has total of 10 fibers)
- The 10 fibers are bundled and read by a single SiPM

# Lateral compact module

Steel tile  $3 \times 3 \times 1.5 \text{ cm}^3$

- Iron radiation length =  $X_0 = 1.757 \text{ cm}$

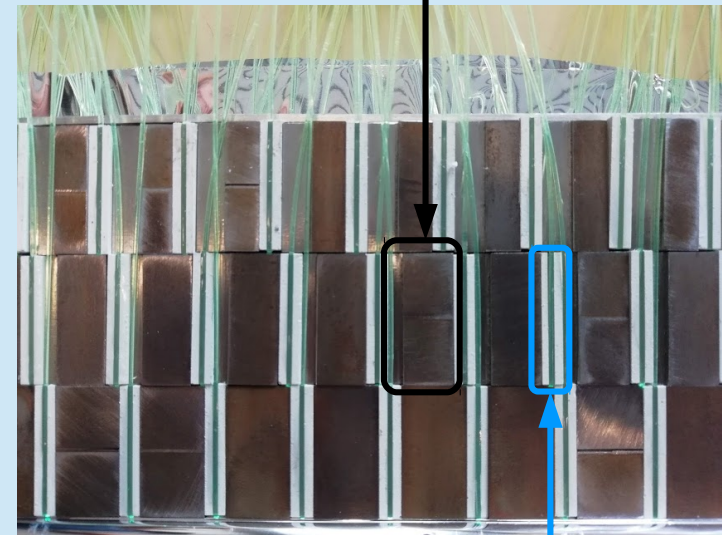
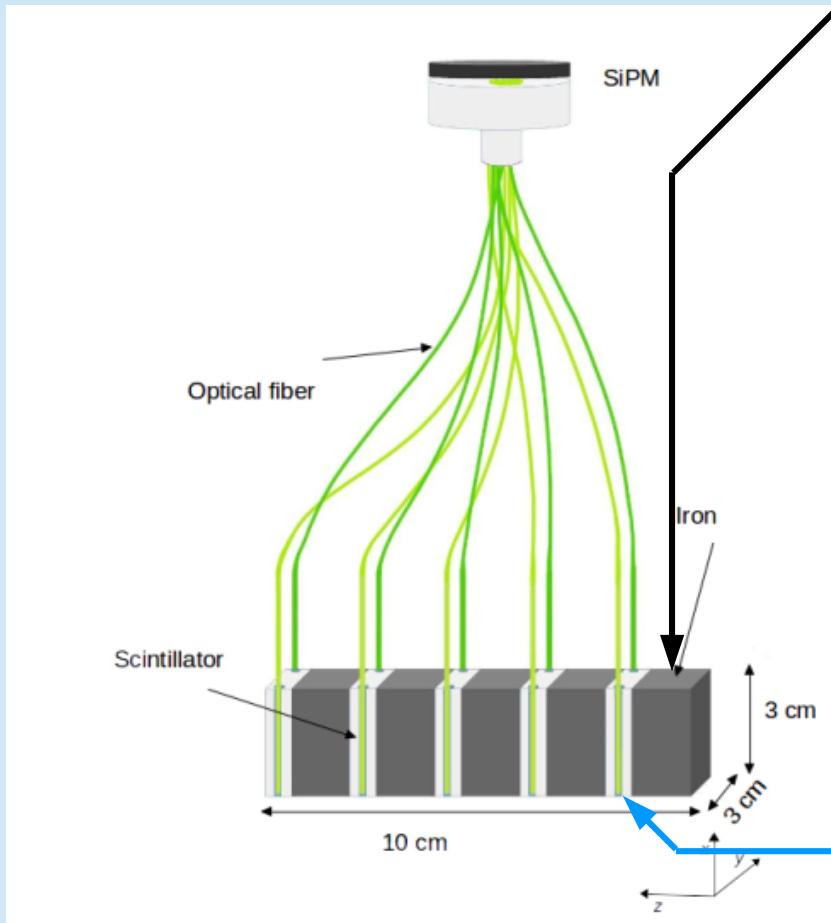

Plastic scintillator tile  $3 \times 3 \times 0.5 \text{ cm}^3$

- Eljen EJ-204
- Scintillation efficiency = 10 400 ph. / 1 MeV  $e^-$
- Emission peak = 408 nm
- Light attenuation length = 160 cm

# Lateral compact module

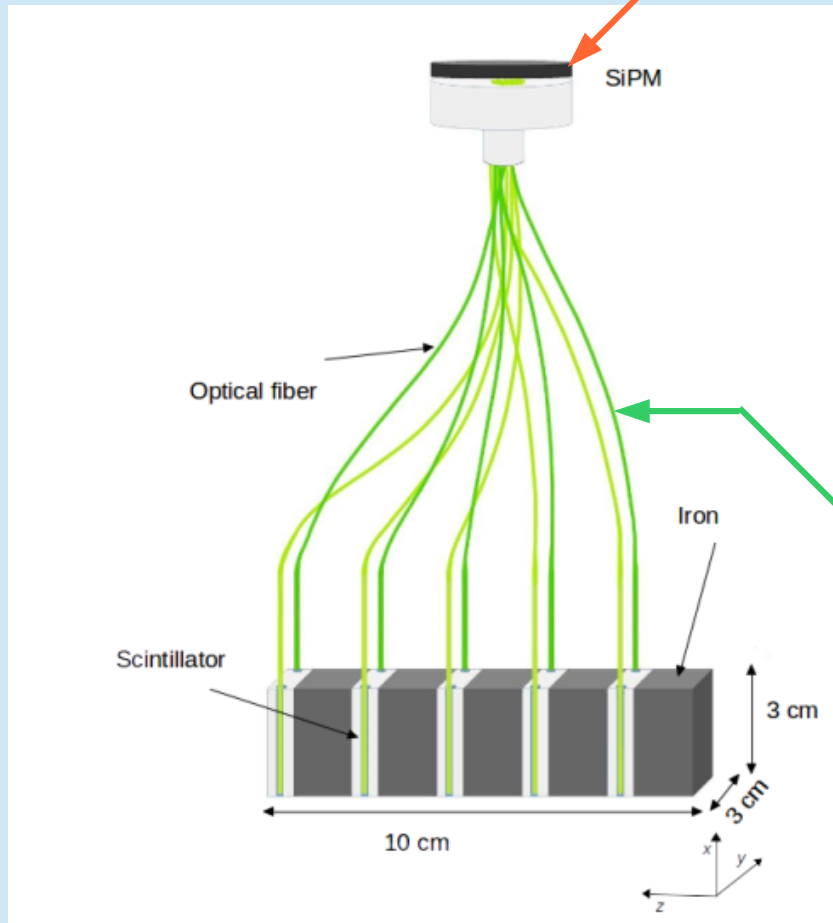

Silicon photomultiplier (SiPM) AdvanSiD ASD-RGB4S-P

- Active area =  $4 \times 4 \text{ mm}^2$
- Cell pitch =  $40 \mu\text{m}$
- Peak sensitivity = 550 nm
- Sensitivity at peak = 32.5% (4V overv.)
- Typical breakdown voltage = 27 V



Blue-to-green wave-length shifting (WLS) optical fibers:

- Diameter = 1 mm
- Kuraray Y11 (Emission peak = 476 nm)
- Saint-Gobain BCF92 (Emission peak = 492 nm)

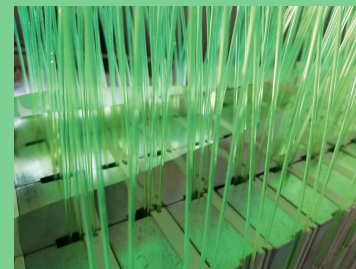

# Lateral readout calorimeter

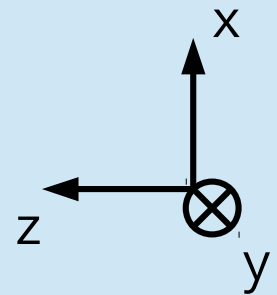

The lateral readout calorimeter is made of 84 LCMs:

- An array of 7 LCMs is displaced along the z direction.
- The 7-LCM array is repeated three times along the x direction, to form a 21-LCM matrix
- The 21-LCM matrix is repeated 4 times in the y direction, forming the bulk of the calorimeter.
- A  $\gamma$ -veto, formed by scintillator doublets, complete the calorimeter structure.
- The bulk of the calorimeter is equipped with 840 optical fibers, bundled into 84 SiPMs.

# Lateral readout calorimeter

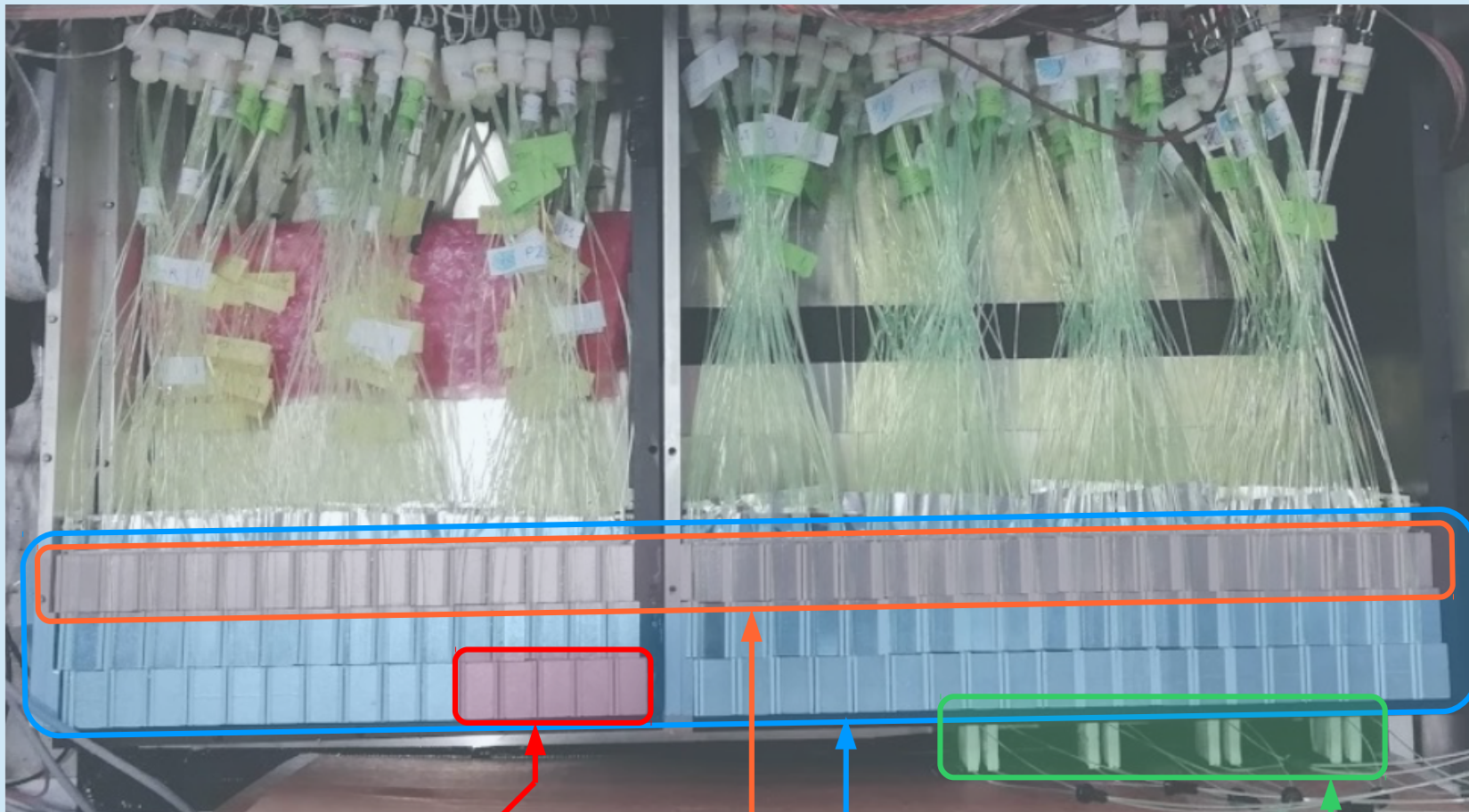

**LCM**

**7-LCM array**

**21-LCM matrix**

(repeat by 4 to obtain  
bulk of calorimeter)

**$\gamma$ -veto**

# Event topology

$e^+$  topology (signal)

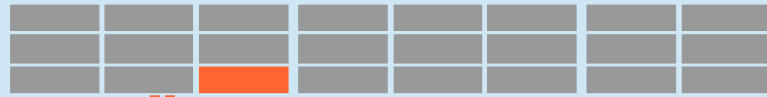

$e^+$



$\pi^0$  topology (backgr.)

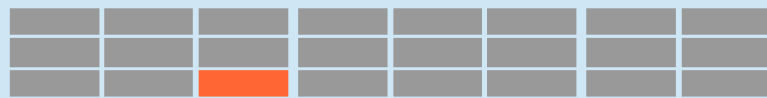

$\pi^0$



$\pi^+$  topology (backgr.)



$\pi^+$



Tagging the beam neutrinos by detecting the associated leptons in the active decay tunnel, is possible only suppressing the background of neutral pions, charged pions, and gammas.

The lateral readout calorimeter is meant to be a portion of the decay tunnel. Its structure and granularity enables the background suppression through the recognition of different event topologies.

$\gamma$ -veto working principle

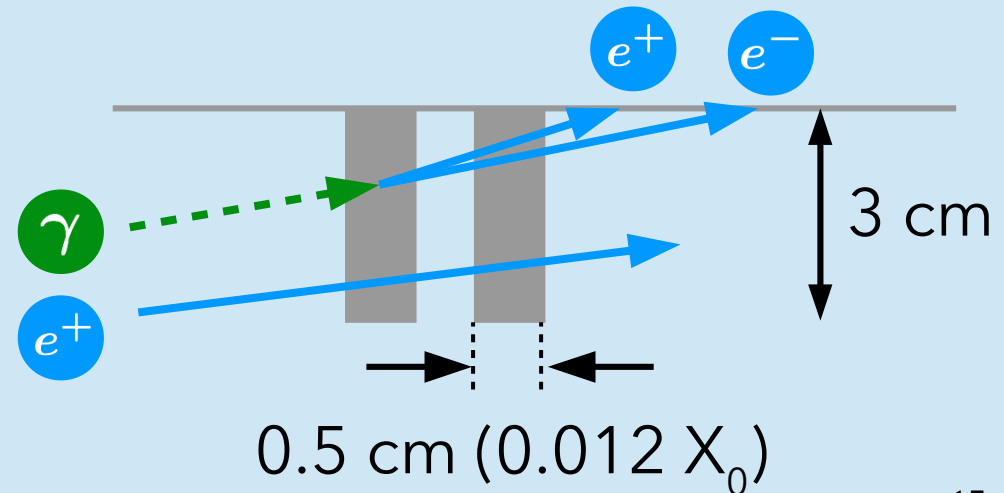

# Event topology

$e^+$  topology (signal)

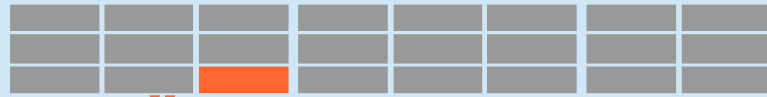

$e^+$

$\pi^0$  topology (backgr.)

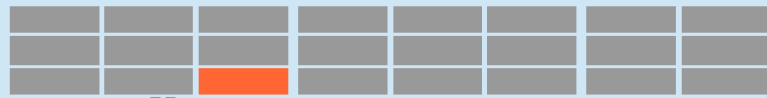

$\pi^0$

$\pi^+$  topology (backgr.)



$\pi^+$

- A single LCM is designed to be sufficient in stopping a positron of the energy of interest (1-3 GeV). This property, together with the  $\gamma$ -veto being fired, defines the positron event.
- A neutral pion immediately decays into 2 gammas. They are converted in their turn into  $e^+e^-$  pairs that stop in a single LCM, as a positron. However, a pair fire the  $\gamma$ -veto with a bigger signal than a positron, permitting the discrimination between positrons and neutral pions.
- A charged pion fires the  $\gamma$ -veto, as a positron does, but it also releases its energy through a shower that fires typically 8 LCMs.

$\gamma$ -veto working principle

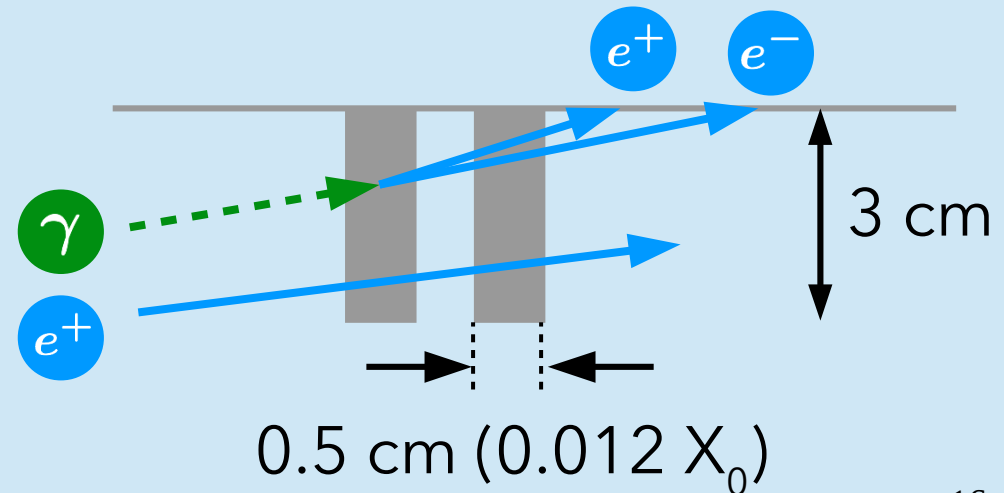



# Testbeam

2018

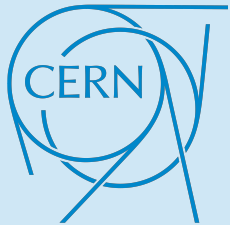

The lateral readout calorimeter is exposed to particle beam at CERN PS-T9 beamline in September 2018. The settings of the experiment are:

- Mixed beam of  $e^-$ ,  $\mu^-$ , and  $\pi^-$
- Beam momentum in the range [1, 5] GeV
- Calorimeter tilted at 0, 50, 100, and 200 mrad with respect to the beam direction
- SiPM bias voltage = 31 V

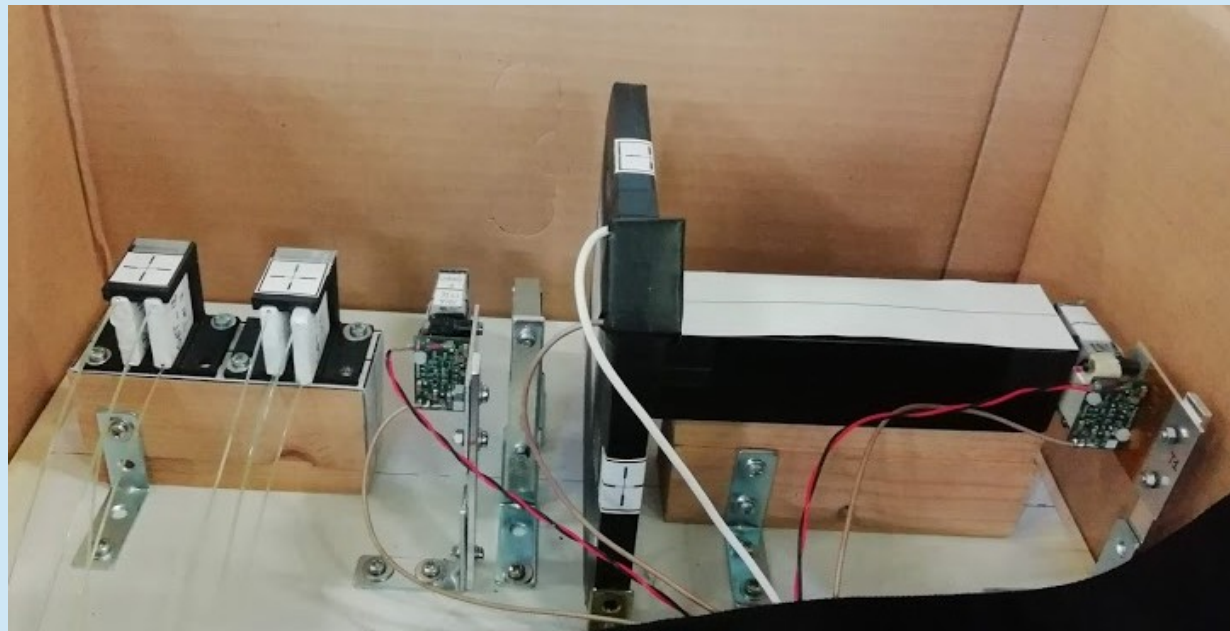

# Energy resolution

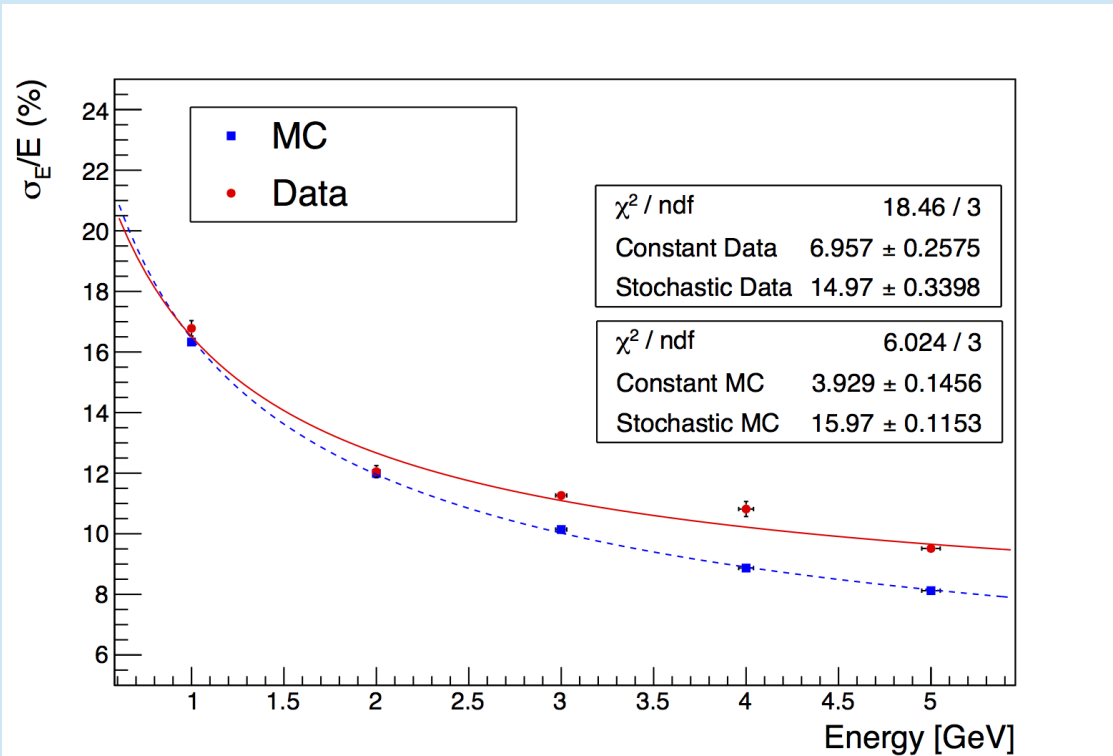

Energy resolution request on the calorimeter for positron tagging and  $e^+/\pi^+$  separation in the range of interest 1 - 3 GeV

$$\frac{\sigma_E}{E} < \frac{25\%}{\sqrt{E(\text{GeV})}}$$

The energy resolution of run at 0 mrad is fit with quadrature sum of stochastic and constant term:

$$\frac{\sigma_E}{E} = \frac{S}{\sqrt{E(\text{GeV})}} \oplus C$$

The energy resolution request is met (17% at 1 GeV)! The data/MC discrepancy at higher energy is due to SiPM saturation.

# SiPM saturation

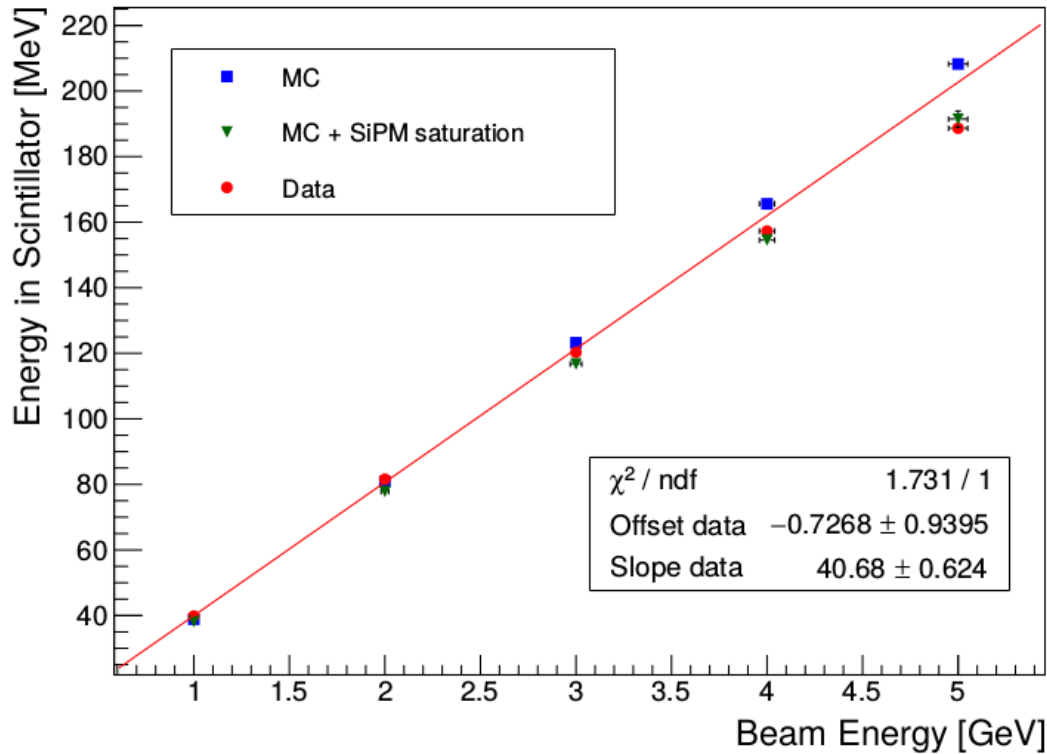

An ideally linear SiPM would have the number of firing cells  $N_{fired}$  equalling the number of impinging photons  $N_{ph}$  able to make a cell fire (rather tautological...)

$$N_{fired} = N_{ph}$$

This linear model (blue squares) cannot explain data (red dots) at high energies.

But ideal SiPMs do not exist! Firstly, the cross-talk probability being  $P_{xt} = 44\%$ , causes a significant magnification of the number of firing cells from  $N_{ph}$  to  $N_{xt}$ .

$$N_{xt} = (1 + P_{xt}) N_{ph}$$

Secondly, the finite number of available cells  $N_{max} = 5000$  limits the response of the SiPM. This saturation effect is modelled with an exponential law.

$$N_{fired} = N_{max} \left[ 1 - \exp\left(-\frac{N_{xt}}{N_{max}}\right) \right]$$

This refined model (green triangles) is able to reproduce data (red dots) at high energies.

# $\gamma$ -veto

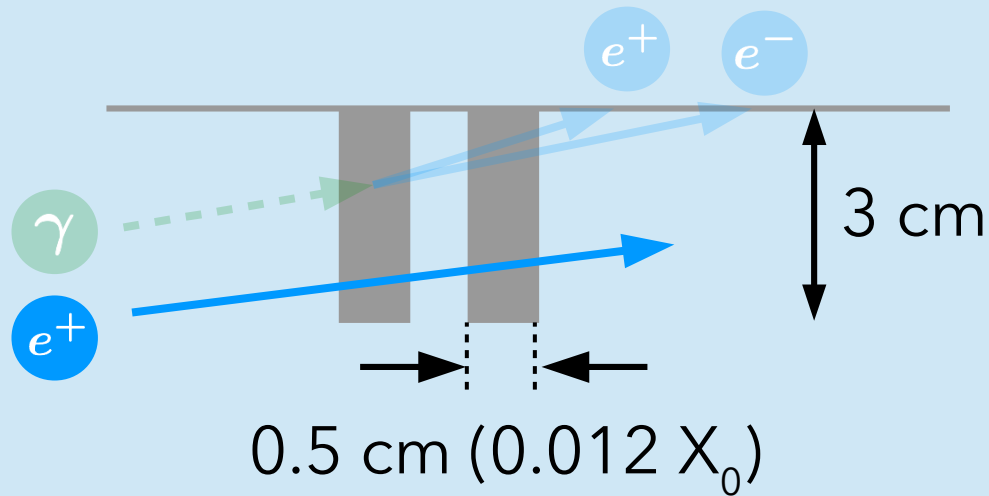

The  $\gamma$ -veto is composed of scintillator doublets located 7 cm apart. This displacement ensures on average the crossing of 5 doublets by a positron from kaon decay.

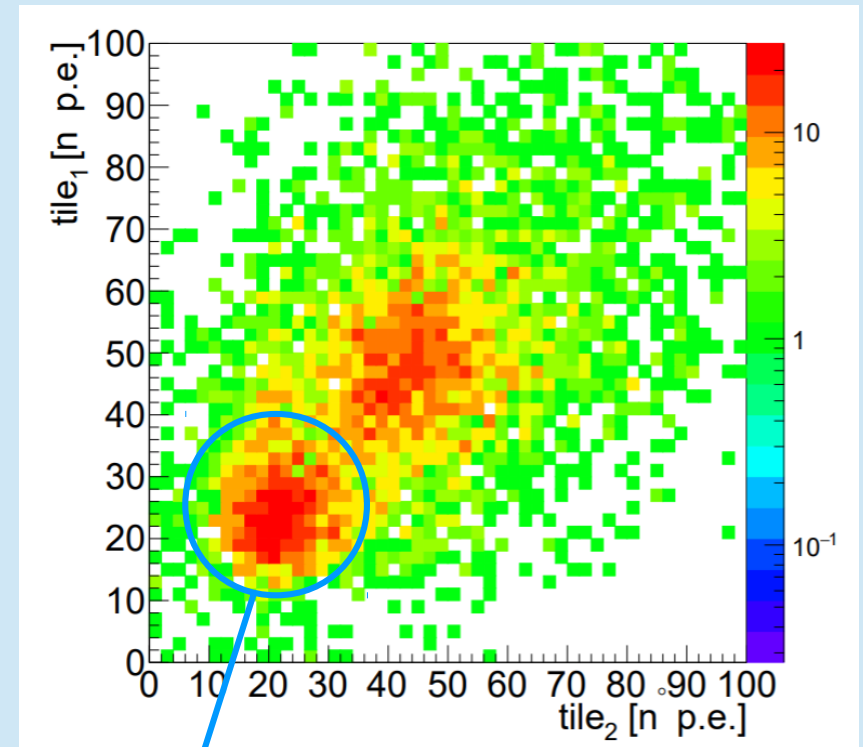

The left blob represents the 1-MIP-like signal of a positron. A single tile performs on average with a signal of 25 p.e. and a time resolution of 0.4 nsec, satisfying the design constrain of 1 nsec.

# $\gamma$ -veto

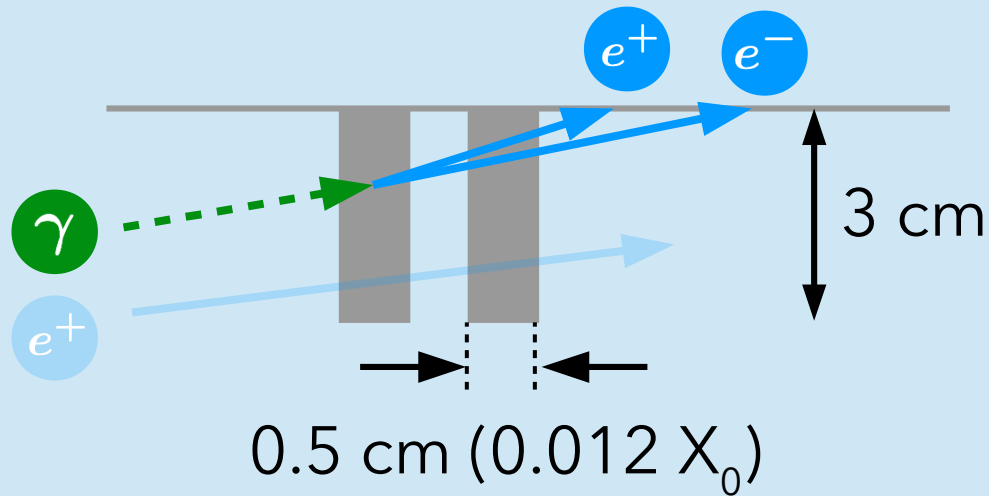

The  $\gamma$ -veto is composed of scintillator doublets located 7 cm apart. This displacement ensures on average the crossing of 5 doublets by a positron from kaon decay.

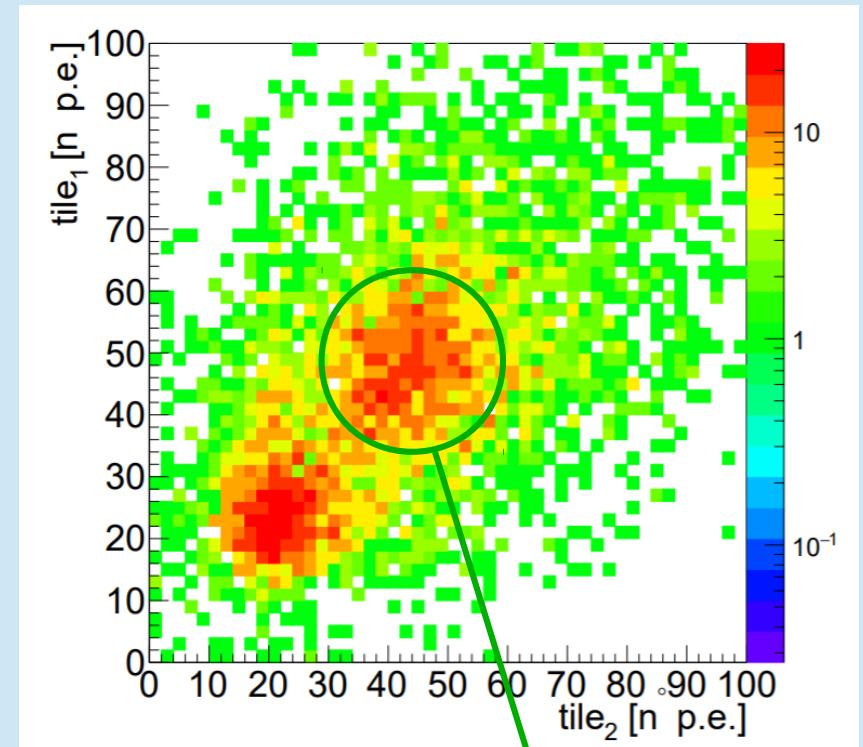

The right blob represents the 2-MIP-like signal of a pair from a  $\gamma$ . A single tile is able to discriminate between positrons (1-MIP-like) and pairs (2-MIP-like) with the following efficiencies:

- 1-MIP-like selecting efficiency = 87 %
- 2-MIP-like background rejection = 89 %
- Corresponding purity = 95 %

---

# Demonstrator

---

1. Physics goal and strategy
2. Lateral readout calorimeter
3. Demonstrator
4. Conclusions

# Demonstrator layout

## Purpose

- Demonstrate the feasibility of lepton reconstruction with a technology scalable up to tens of meters.

## Dimensions

- 1.65 m length
- 90° azimuth

## Composition

- 75 layers of iron (15 mm thick)
- 75 layers of scintillator (7 mm thick)
- 15 × 3 LCM
- The calorimetric portion (iron+scintillator) is coated by a 30 cm deep cover of 5% borated polyethylene, in order to shield the SiPMs from the neutrons

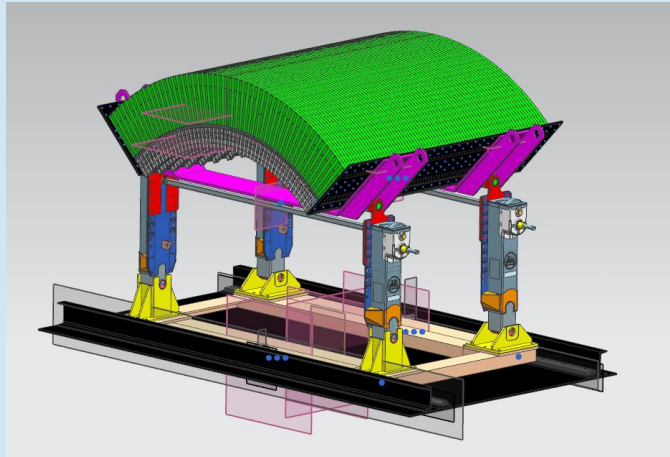

## Instrumentation

- The central 45° will be instrumented with SiPMs and readout electronics
- Remaining 45° kept for mechanical considerations
- Designed to be extendable to  $2\pi$  structure

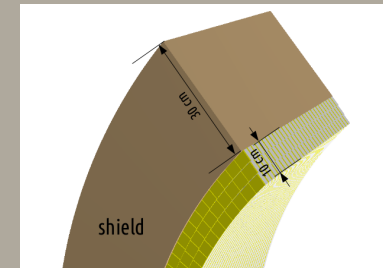

Iron layers and borated polyethylene layers available at INFN-LNL for assembly

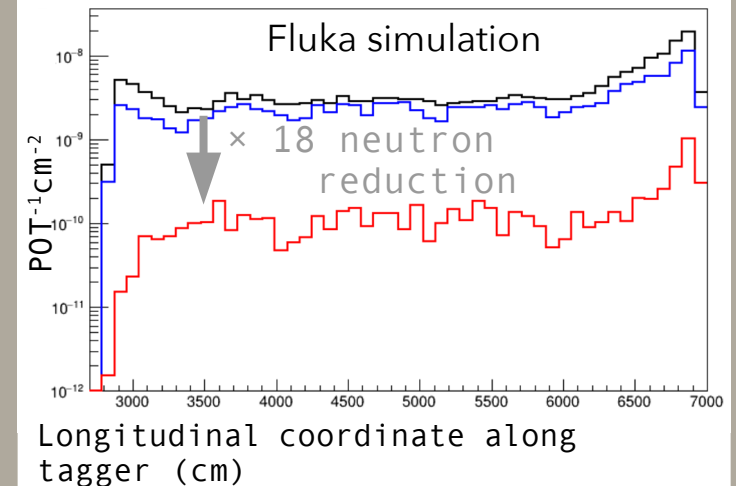

# Scintillator-to-fiber coupling

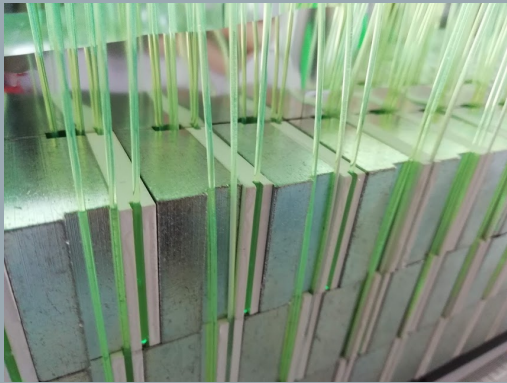

Old solution (lateral readout calorimeter): fibers collect the scintillation light laterally

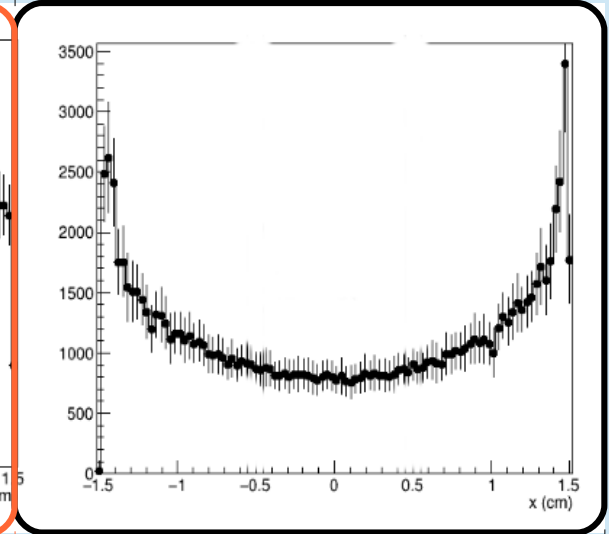
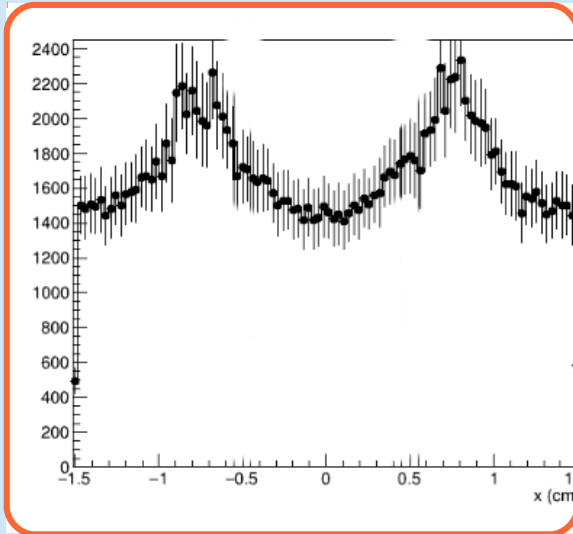

New solution (demonstrator): fibers collect the scintillation light frontally (fibers 1.5 cm apart)

Advantages of new coupling scheme, validated with GEANT4 simulation:

- More light collection
- More uniform

Additional advantage:

- Enables a new fiber routing scheme (next slide).

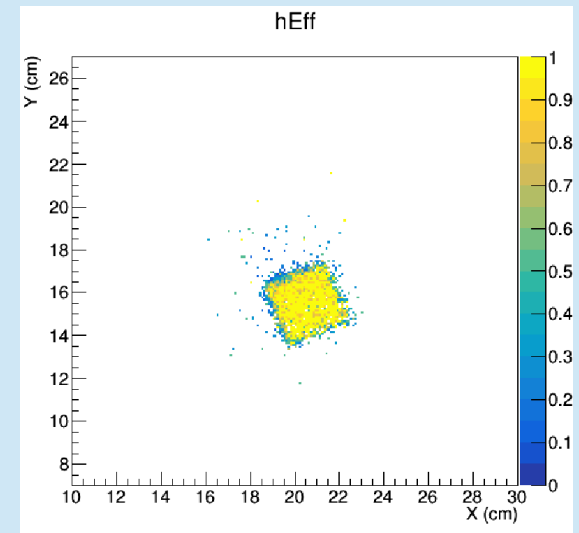

Uniformity checked with cosmic-ray data



# Enubino

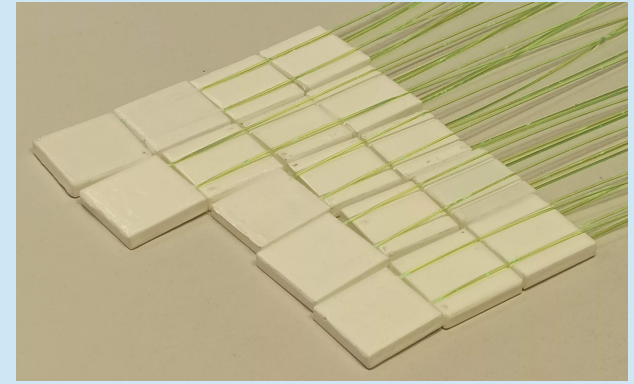

Enubino is the prototype of a single azimuthal unit of the demonstrator (3 LCM). Its construction proved:

- The assembly of the scintillators with the new scheme (quadruplets with  $\gamma$ -veto, triplets without  $\gamma$ -veto)
- Routing of the fibers through the borated polyethylene
- Readout of bundled fibers by SiPMs

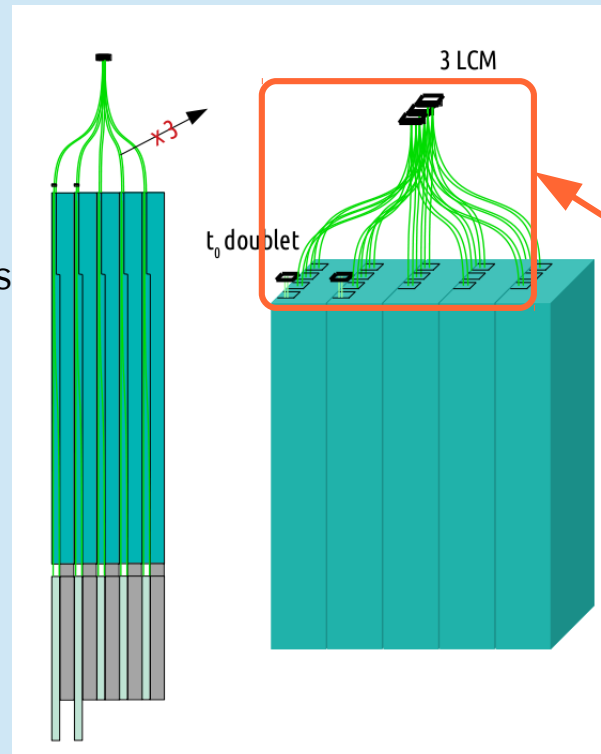

Scintillator and fiber routing at the finalization phase:

- Final tiles done by UNIPLAST (Moscow) in collaboration with INR group.
- Fiber routing cap at the end of neutron shield ensures correct bundling.

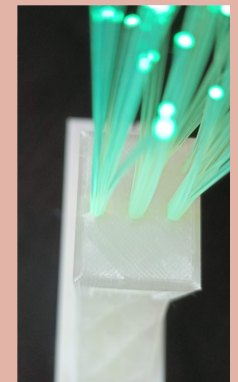

# Enubino cosmic rays setup

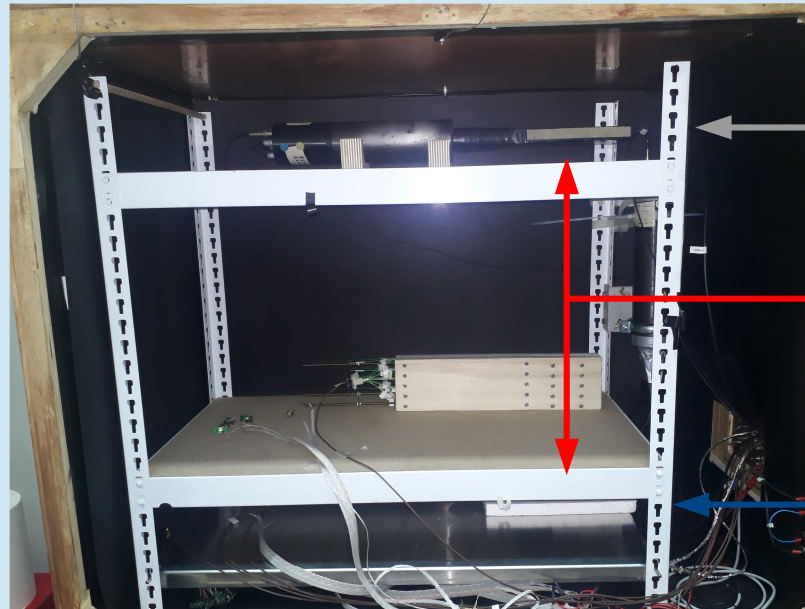
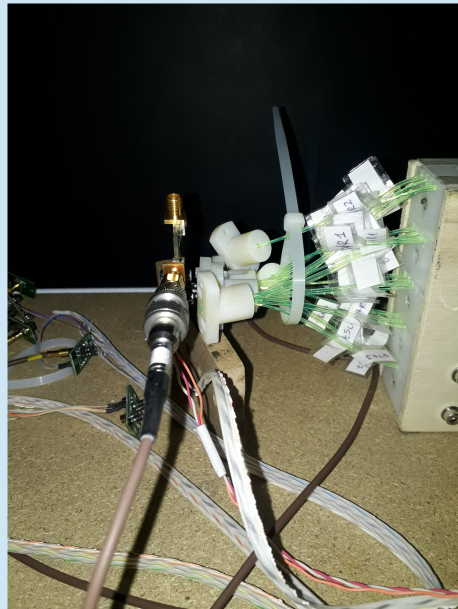

TRGTOP

TRG distance 60.5 cm

TRGBOT

Enubino cosmic rays setup:

- Enubino is displaced in a dark box and one channel is read by a SiPM.
- The SiPM signal is amplified and digitized for further analysis.
- The trigger is provided by the processed signals of two scintillators read through PMTs.

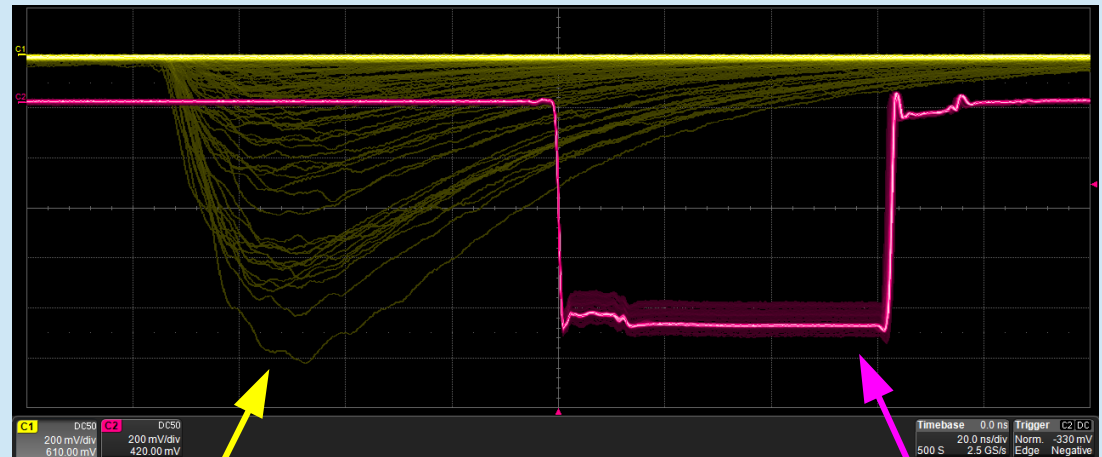

Cosmic rays signals from Enubino (Amplified SiPM)

Trigger signals

# Electronics



## Custom readout electronics

It consists of:

- 4-channel ADC board (ADS4249: 250 MS/s, 14 bits)
- Digital board to handle signals with FPGA (Altera 5CGXBC3B6F23I7N)

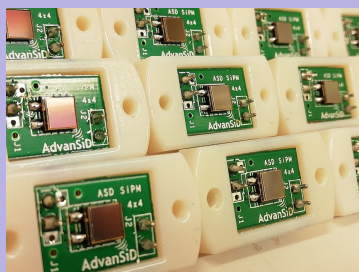

AdvanSiD ASD-RGB4S-P

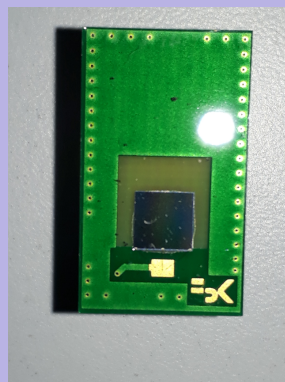
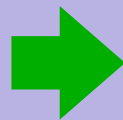

FBK RGB-HD

## SiPM migration

From 40  $\mu\text{m}$  cell SiPM to 30  $\mu\text{m}$  cell SiPM in order to increase cell count and avoid saturation.

Validation measurements using:

- Blue laser
- Cosmic-rays intercepted by calorimeters (lateral readout and E nubino)

---

# Conclusions

---

1. Physics goal and strategy
2. Lateral readout calorimeter
3. Demonstrator
4. Conclusions

# Conclusions

- Enubet started as a ERC grant in 2016, in order to validate both in simulation and hardware the possibility of a monitored  $\nu$  beam by lepton tagging in an active decay volume.
- The project has undergone various phases of R&D, whose milestones consisted in the construction of different prototypal calorimeters, and the assessment of their performance.
- Fast timing, sufficient energy resolution, radiation tolerance (in general, and more specifically neutron shielding), fiber coupling and routing, mechanical stability, electronics development are the core aspects that naturally drove along the years the R&D of the Enubet project.
- The knowledge gained in the past years is converging in the construction of the *demonstrator*, which is a 1.65 m, 90° portion of the active decay tunnel. The *demonstrator* will be exposed to particle beam at CERN in 2022.

# References

- The ERC ENUBET Project site: <https://enubet.pd.infn.it/>
- A. Berra et al. [ENUBET Collaboration], Enabling precise measurements of flux in accelerator neutrino beams: the ENUBET project, CERN-SPSC-2016-036; SPSC-EOI-014
- F. Acerbi et al., CERN-SPSC-2018-034, SPSC-I-248, Geneva, 2018
- F. Acerbi et al., CERN-SPSC-2021-013, SPSC-SR-290, Geneva, 2021
- F. Pupilli et al., Positron identification in the ENUBET instrumented decay tunnel, PoS NEU-TEL2017 (2018) 078
- F. Acerbi et al., The ENUBET positron tagger prototype: construction and testbeam performance, JINST 15 P08001, 2020
- G. Ballerini et al., Test beam performance of a shashlik calorimeter with fine-grained longitudinal segmentation, JINST 13 P01028, 2018
- A. Longhin, L. Ludovici and F. Terranova, A novel technique for the measurement of the electron neutrino cross section, Eur. Phys. J. C 75 155, 2015