

The ENUBET experiment and its implementation at CERN

F. Terranova^(*) on behalf of the ENUBET Collaboration

(*) University of Milano-Bicocca & INFN Milano-Bicocca

The rationale of ENUBET



The knowledge of neutrino cross section is stuck at 10-30 % level and the needs of the neutrino community are at 1% level because:

- Leading systematics for long baseline experiments → Neutrino Oscillation Physics
- Limited possibility to validate nuclear electroweak effects (“nucleus and nuclear correction”) → Electroweak physics
- Neutrino generators based on different approach still provide results with >50% discrepancies → Nuclear Physics

From the **European Strategy for Particle Physics Deliberation document**:

To extract the most physics from DUNE and Hyper-Kamiokande, a complementary programme of experimentation to determine neutrino cross-sections and fluxes is required. Several experiments aimed at determining neutrino fluxes exist worldwide. The possible implementation and impact of a facility to measure neutrino cross-sections at the percent level should continue to be studied.

From the Physics Briefbook for the **European Strategy for Particle Physics (arXiv:1910.11775)**

Both nSTORM and ENUBET are to a large extent site-independent concepts, studies and R&D; however both consider a possible implementation at CERN. For nSTORM, under the auspices of the PBC program, an initial study of implementation at CERN was carried out, and no showstoppers have been identified. For ENUBET the option of using SPS as the proton driver has been considered in greater detail with a possible site in the North Area and the ProtoDUNEs as neutrino detectors.

A dedicated study should be set-up to evaluate the possible implementation, performance and impact of a percent-level electron and muon neutrino cross-section measurement facility (based on e.g. ENUBET or nSTORM) with conclusion in a few years time.

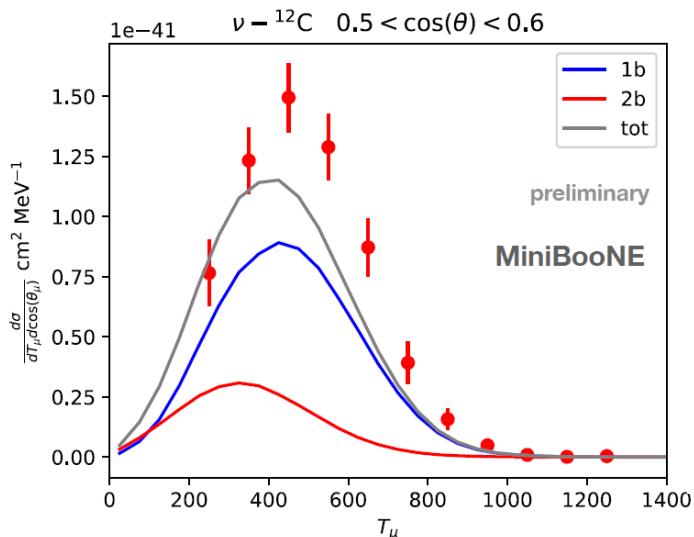
A harmful ignorance

- Major impact on the sensitivity of DUNE and HyperKamiokande (already dominant in T2K...)

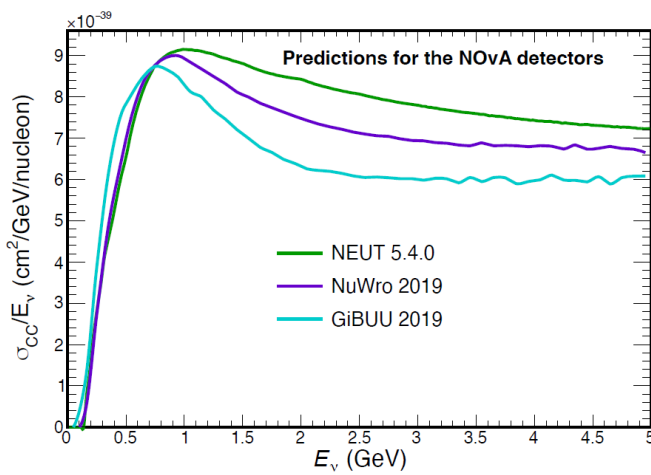
T2K

| Beam mode | Systematic uncertainties | | |
|---------------|--------------------------|---------------|-------------------|
| | Neutrino | | |
| SK sample | 1 Ring μ -like | 1 Ring e-like | 1 Ring e-like 1de |
| Flux | 5.1% | 4.8% | 4.9% |
| Cross-section | 10.1% | 10.3% | 12.0% |
| SK | 2.9% | 4.4% | 13.4% |

- Modeling of nuclear effects in neutrino interactions

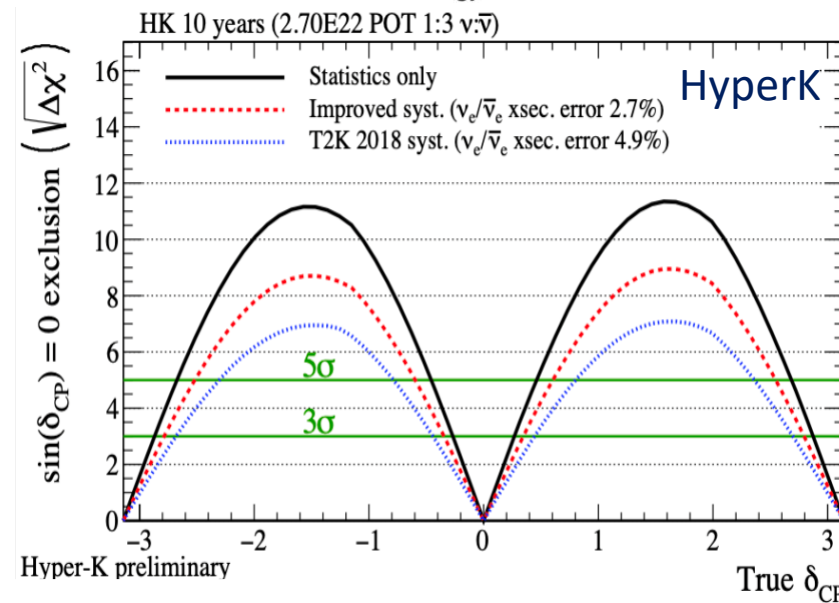
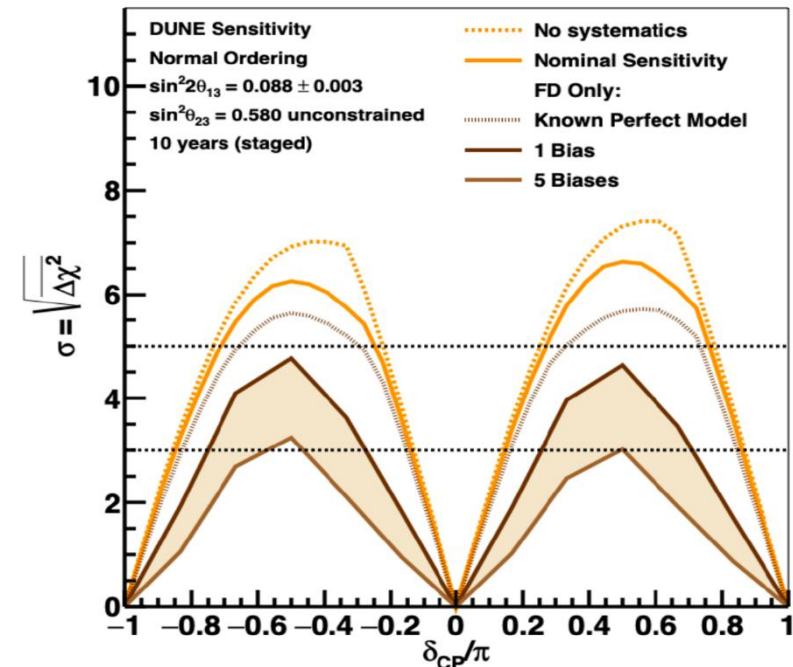


N. Rocco, Nufact2022



J. Paley, Nufact2022

DUNE



What is needed for a new generation cross-section facility?



- Measure the neutrino flux of a xsect-dedicated short baseline beam with a precision $<1\%$ in ν_e and ν_μ . **Flux** is the dominant systematics. Generally known at 10% level with a few notable exceptions
 - Combine hadroproduction data + ν -e scattering (5-10%). World record: arXiv:2209.05540 (3.3-4.7% !)
 - Monitored neutrino beam (this talk) 0.5-1 %
 - Muon storage ring (nuSTORM) $<1\%$
- Measure the **energy** of the neutrino without relying on the final state to get rid of all biases coming from nuclear reinteractions
 - Narrow band beams combined with movable detectors (rough approximation of a “monochromatic beam”)
 - Monitored neutrino beam “Narrow band- off-axis technique” (this talk)
- Use the same **target** as DUNE and HyperK + low Z target (existing or new experiments)
 - Some information available from near detectors (but, then, issues with flux \times cross-section deconvolution)
 - New experiments with existing or novel detectors along a short-baseline beam (following the success of dedicated experiments like Minerva)
- **Statistics** (double differential cross sections)
 - Not an issue for ν_μ . $O(10^4)$ ν_e in conventional beams and monitored neutrino beams
 - $O(10^6)$ in all flavors using muon storage rings (nuSTORM)

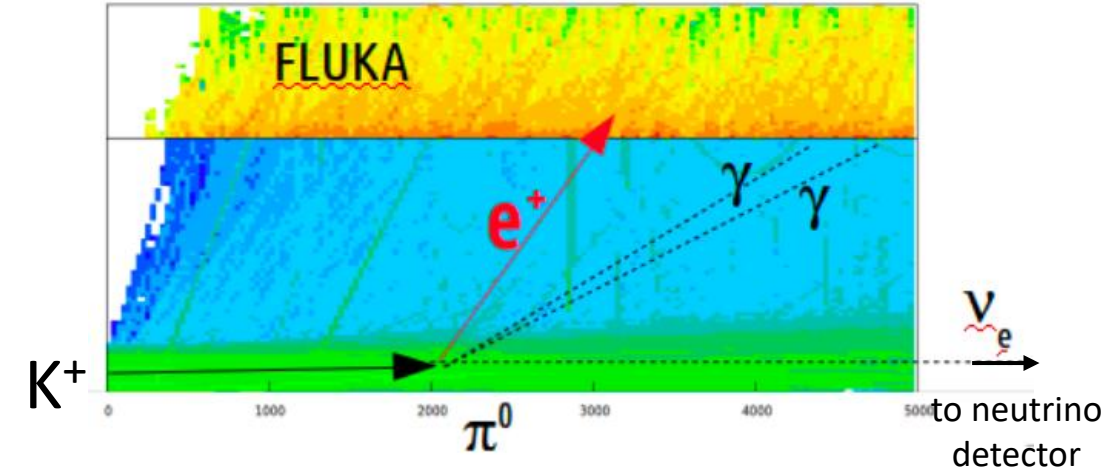
What is ENUBET?



ENUBET is the project for the realization of the first monitored neutrino beam.

“Monitored neutrino beams are beams where diagnostic can directly measure the flux of neutrinos because the experimenters monitor the production of the lepton associated with the neutrino at the single-particle level.”

(Wikipedia)



- ❖ ENUBET: ERC Consolidator Grant, June 2016 – May 2021 (COVID: extended to end 2022). **PI: A. Longhin;**
- ❖ Since April 2019: CERN Neutrino Platform Experiment – NP06/ENUBET – and part of Physics Beyond Colliders;
- ❖ Collaboration: 65 physicists & 13 institutions; Spokespersons: A. Longhin, F. Terranova; Technical Coordinator: V. Mascagna;

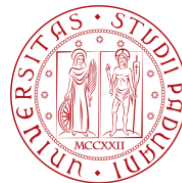
Visit our webpage for further info and material!

<https://www.pd.infn.it/eng/enubet/>



ENUBET

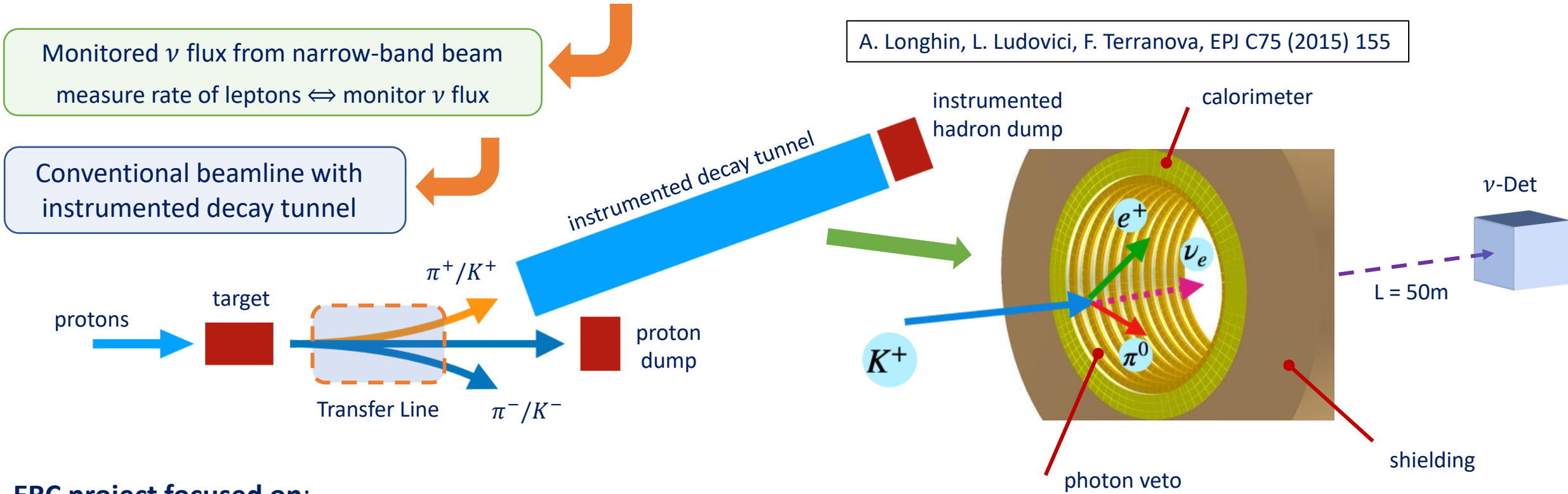
Enhanced Neutrino BEams from kaon Tagging



ENUBET: the first monitored neutrino beams

How do we achieve such a precision on the neutrino cross-section, flavor composition and energy?

A. Longhin, L. Ludovici, F. Terranova, EPJ C75 (2015) 155



Monitored ν flux from narrow-band beam
measure rate of leptons \Leftrightarrow monitor ν flux

Conventional beamline with
instrumented decay tunnel

- ❖ ERC project focused on:
measure positrons (instrumented decay tunnel) from $K_{e3} \Rightarrow$ determination of ν_e flux;
- ❖ As CERN NP06 project:
extend measure to muons (instrumented decay tunnel) from $K_{\mu\nu}$ and (replacing hadron dump with range meter) $\pi_{\mu\nu} \Rightarrow$ determination of ν_μ flux;

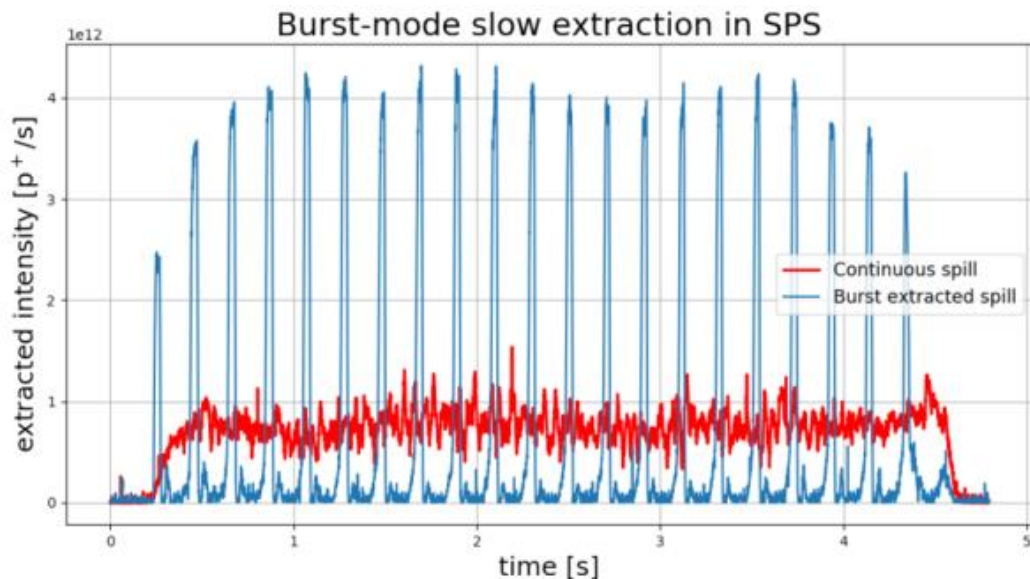
Main systematics contributions are bypassed: hadron production, beamline geometry & focusing, POT;

The 2020 breakthrough: a high-intensity horn-less neutrino beam



When we first proposed ENUBET, we were aiming at a beam where the leptons in the decay tunnel are produced at **slow rate** because we were afraid of pile-up and saturation of the instrumentation in the tunnel

Original design: a horn pulsed every 100 ms with a 10 ms pulse (“burst proton extraction”)



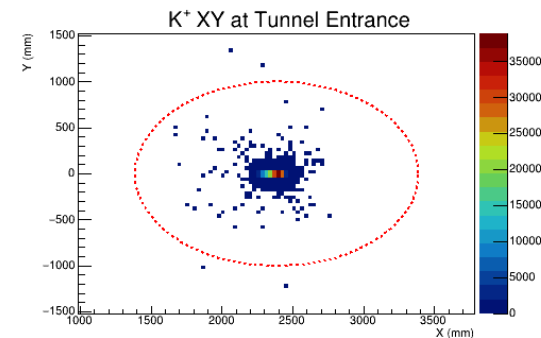
First demonstration of this proton extraction scheme in 2018 at CERN-SPS

M. Pari, M. A Fraser et al, IPAC2019

2020 design (“static focusing system”): a neutrino beam without a horn where focusing at 8 GeV/c is accomplished by quadrupoles (like e.g. NuTeV but at much lower energy!)

The design was so successful that it achieved a flux that is just 2 times smaller than the corresponding horn-based design but protons are extracted in 2 seconds!! Rates reduced by more than one order of magnitude!

The ENUBET beamline (details in A. Branca ICHEP2022)



Rates @ Tunnel entrance for 400 GeV POT

| π^+ [10^{-3}]/POT | K^+ [10^{-3}]/POT |
|---------------------------|-------------------------|
| 4.13 | 0.34 |



~1.5X w.r.t. previous results

Transfer Line

- normal conducting magnets;
- quadrupoles + 2 dipoles (1.8 T, total bending of 14.8°);
- short to minimize early K decays;
- small beam size;

Tagger (decay tunnel)

- length of 40 m;
- radius of 1 m;

Dumps

primary protons

Large bending angle of 14.8°:

- better collimated beam + reduced muons background + reduced ν_e from early decays;

Transfer Line:

- optics optimization w/ **TRANSPORT** (5% momentum bite centered @ 8.5 GeV) **G4Beamline** for particle transport and interactions;
- **FLUKA** for irradiation studies, **absorbers and rock** volumes included in simulation (not shown above);
- **optimized graphite target** 70 cm long & 3 cm radius (dedicated studies, scan geometry and different materials);
- **tungsten foil downstream target** to suppress positron background;
- tungsten alloy **absorber @ tagger entrance** to suppress backgrounds;

Dumps:

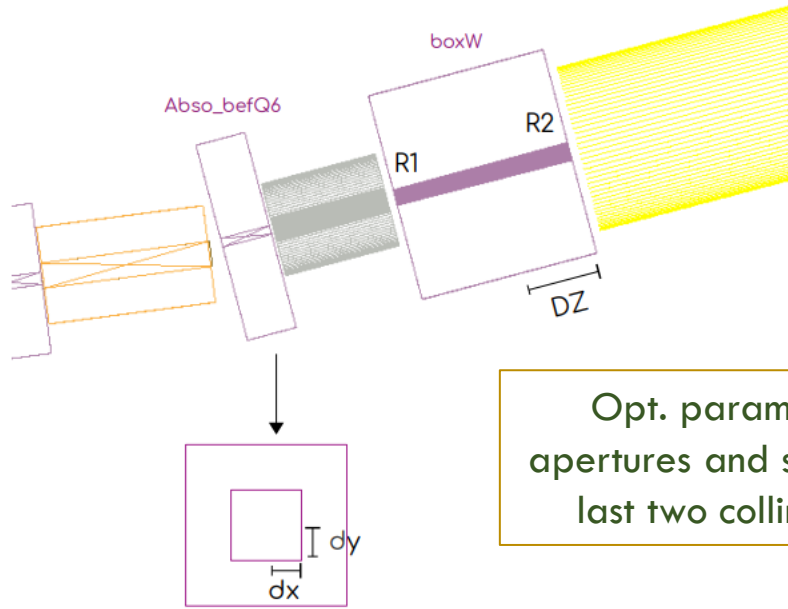
- **Proton dump**: three cylindrical layers (graphite core -> aluminum layer -> iron layer);
- **Hadron dump**: same structure of the proton dump -> allows to reduce backscattering flux in tunnel;

Full facility implemented in GEANT4:

- Control over all parameters;
 - Access to the particles histories;
- assessment of the nu flux systematics

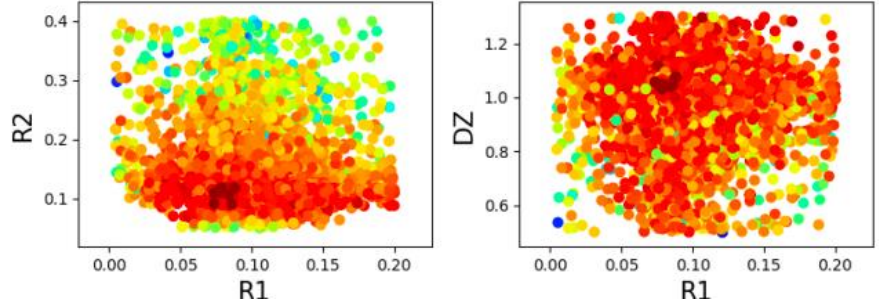
The ENUBET beamline: optimization studies

These are the ICHEP2022 results. Optimization completed in Oct 2022. Final results in Jan 2023



Opt. parameters: apertures and shapes of last two collimators

FOM dependence on opt. parameters



FOM = signal/background
Signal: π & K @ tagger entrance
Background: e^+ & π hitting tunnel walls

An optimization campaign is ongoing:

- Goal:** further improvement of the π/K flux at tunnel entrance while keeping background level low;
- Strategy:** scan parameters space of beamline to maximize FOM;
- Tools:** full facility implemented in Geant4 -> control with external cards all parameters -> systematic optimization with developed framework based on genetic algorithm;

| Rates @ Tunnel entrance for 400 GeV POT | π^+ [10^{-3}]/POT | K^+ [10^{-3}]/POT |
|---|---------------------------|-------------------------|
| Design | 4.13 | 0.34 |
| Optimized | 5.27 | 0.44 |

| Background hitting tunnel walls | e^+ [10^{-3}]/ K^+ | π^+ [10^{-3}]/ K^+ |
|---------------------------------|----------------------------|------------------------------|
| Design | 7 | 59 |
| Optimized | 2 | 35 |

Preliminary

Preliminary

- About 28% gain in flux -> **2.4 years** to collect $10^4 \nu_e^{CC}$;
- Reduced backgrounds, but similar to signal shapes -> next step: improve FOM definition (include sgn/bkg distributions);

Preliminary

ν_e^{CC} energy distribution @ detector

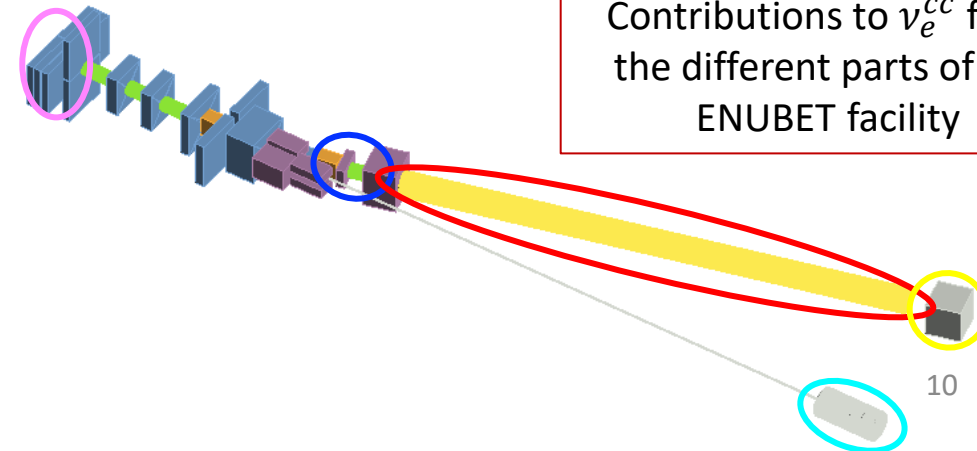
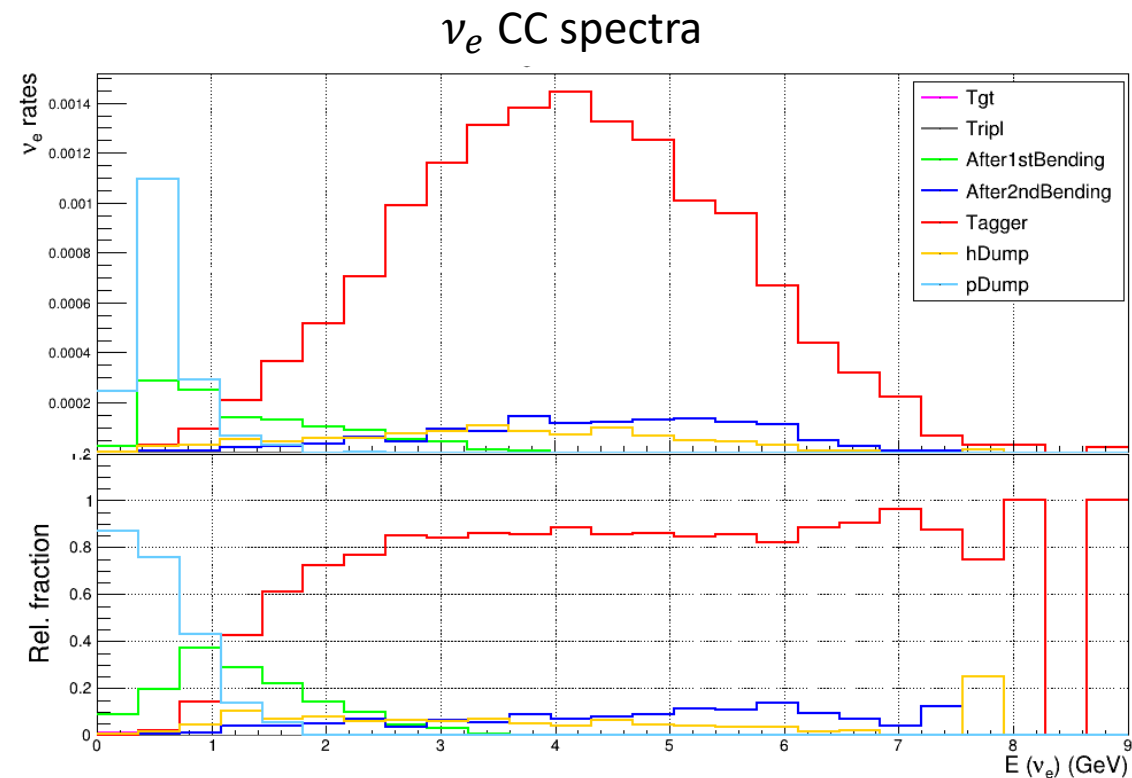
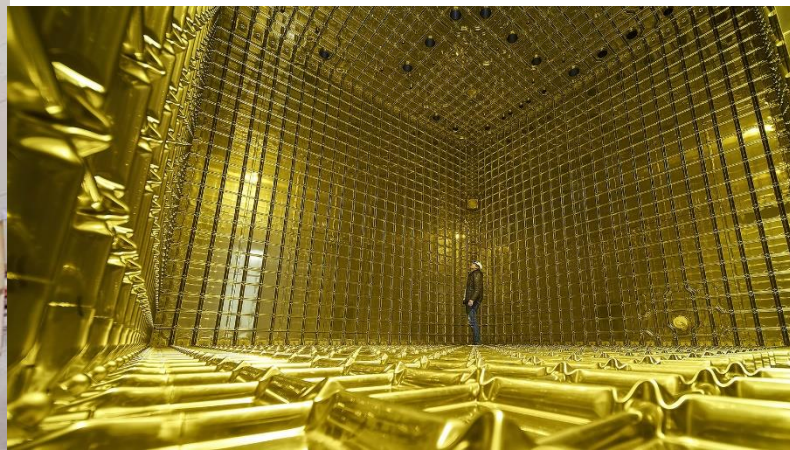


A total ν_e^{CC} statistics of 10^4 events in ~ 2 years (aim of the optimization: $9 \cdot 10^{19}$ pot if implemented at CERN SPS)

- @ SPS with $4.5 \cdot 10^{19}$ POT/year;
- 500 tonne detector @ 50 m from tunnel end;



ProtoDUNE-SP (NP04)



ν_{μ}^{CC} energy distribution @ detector



Narrow-band off-axis Technique

Narrow momentum beam O(5-10%)

(E_{ν}, R) are strongly correlated

E_{ν} = neutrino energy;

R = radial distance of interaction vertex from beam axis;

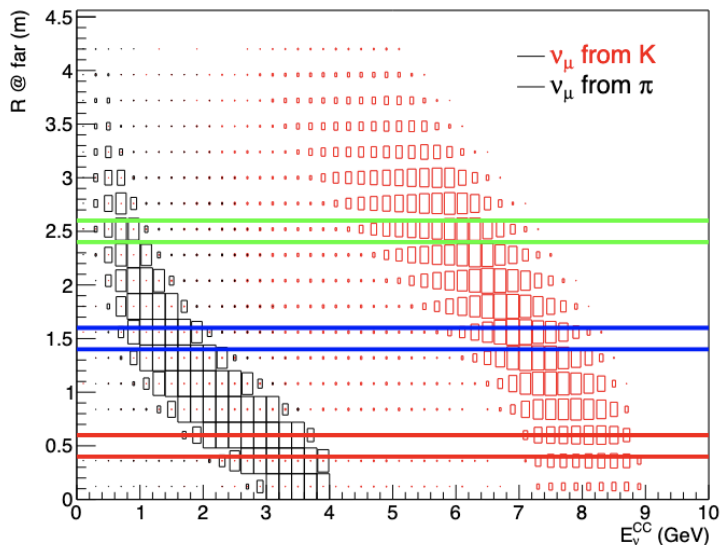
F. Acerbi et al., CERN-SPSC-2018-034

Precise determination of E_{ν} :
no need to rely on final state particles from ν_{μ}^{CC} interaction

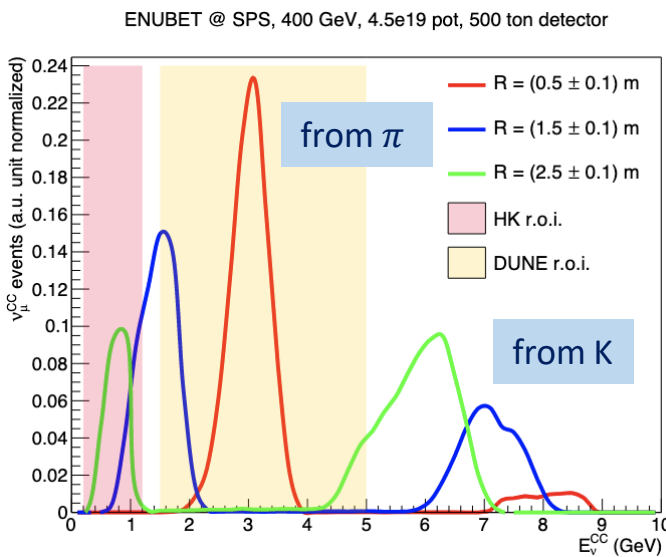
8-25% E_{ν} resolution from π in the DUNE energy range

30% E_{ν} resolution from π in HyperK energy range (DUNE optimized TL w/ 8.5 GeV beam):

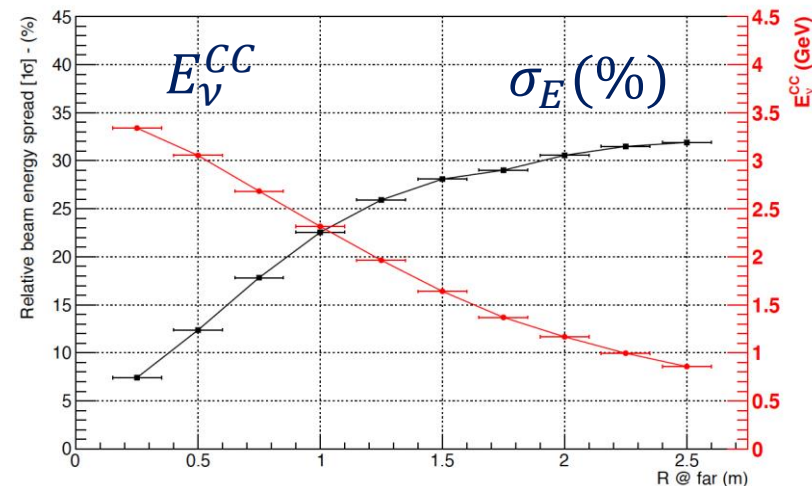
- ongoing R&D: Multi-Momentum Beamline (4.5, 6 and 8.5 GeV) => HyperK & DUNE optimized;



select slices in R windows



π /K populations well separated



from pion peaks at different R

Decay tunnel instrumentation

Shielding

- ❖ 30 cm of borated polyethylene;
- ❖ SiPMs installed on top -> factor 18 reduction in neutron fluence;

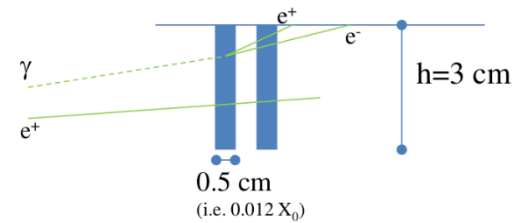
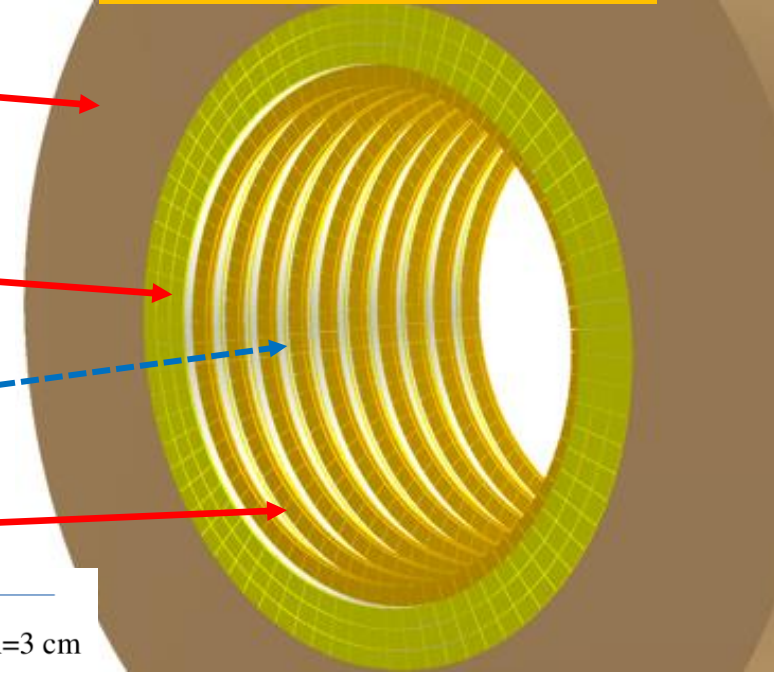
Calorimeter with $e/\pi/\mu$ separation capabilities:

- ❖ sampling calorimeter: sandwich of plastic scintillators and iron absorbers;
- ❖ three radial layers of LCM / longitudinal segmentation;
- ❖ WLS-fibers/SiPMs for light collection/readout;

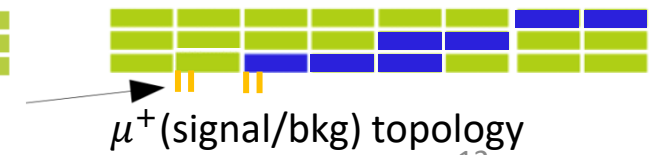
Photon-Veto allows π^0 rejection and timing:

- ❖ plastic scintillator tiles arranged in doublets forming inner rings;
- ❖ time resolution of ~ 400 ps;

Calorimeter layout



Exploit event topology for PID

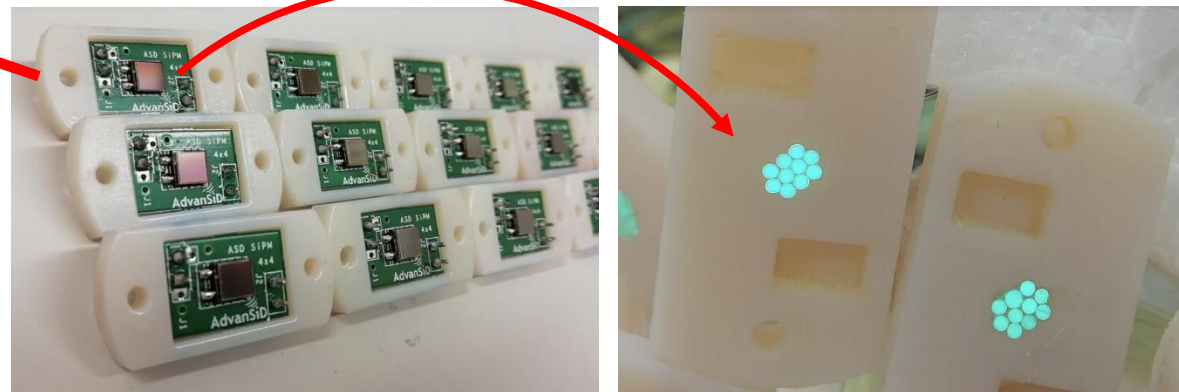


Decay tunnel instrumentation prototype & tests

Prototype of sampling calorimeter built out of LCM with lateral WLS-fibers for light collection



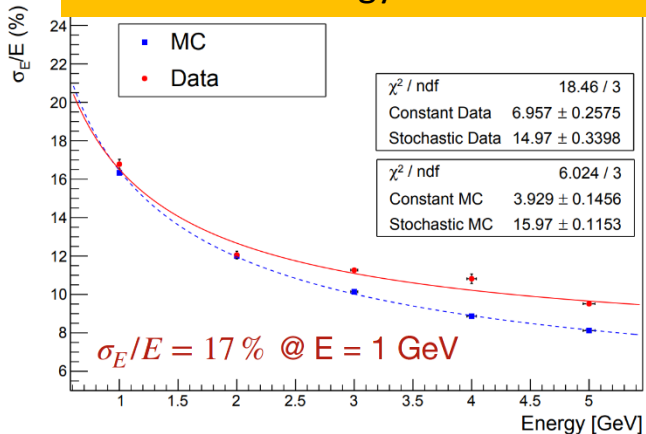
Large SiPM area (4x4 mm²) for 10 WLS readout (1 LCM)



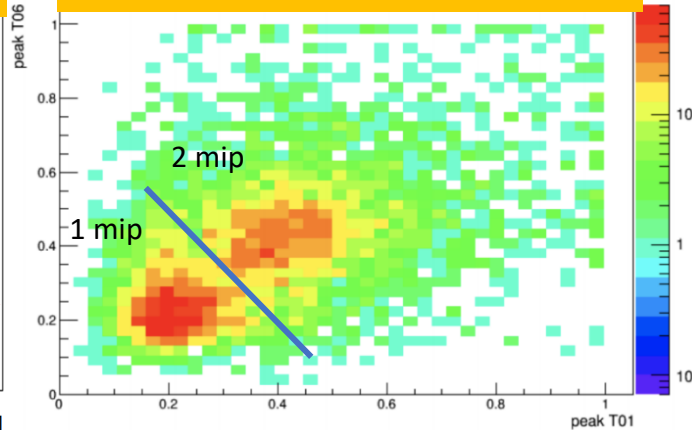
SiPMs installed outside of calorimeter, above shielding: avoid hadronic shower and reduce (factor 18) aging

Tested during 2018 test-beams runs @ CERN TS-P9

Electron energy resolution



1mip/2mip separation



Status of calorimeter:

- ✓ longitudinally segmented calorimeter prototype successfully tested;
- ✓ photon veto successfully tested;
- custom digitizers: **in progress**;

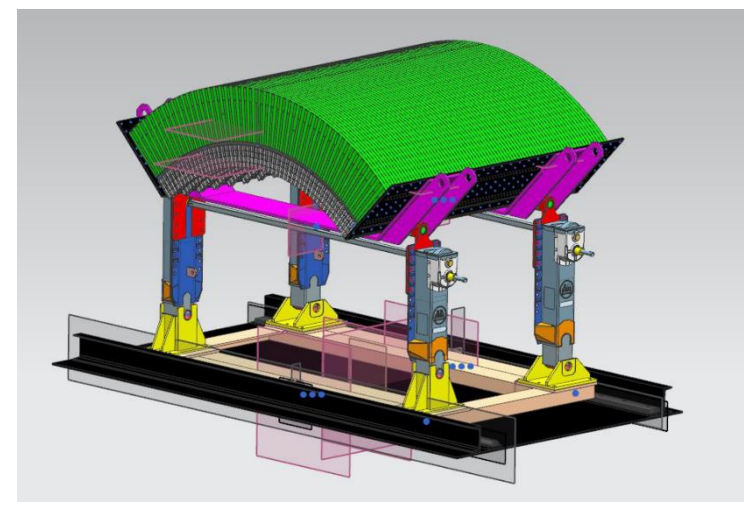
Choice of technology: finalized and cost-effective!

The ENUBET demonstrator

Construction @ LNL-INFN Labs



Iron arcs and borated polyethylene shielding

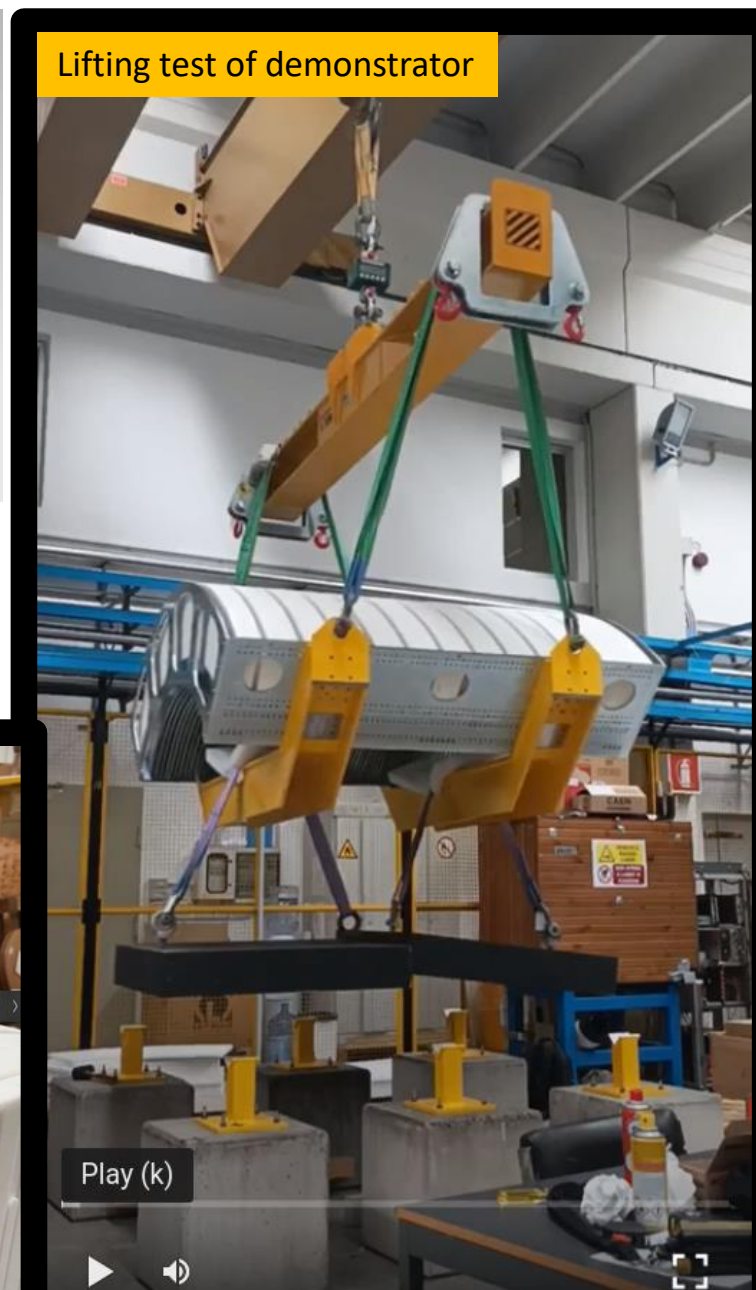


A. Branca

Fiber concentrator (bonding/routing to SiPMs)



INPC2022 - 11-

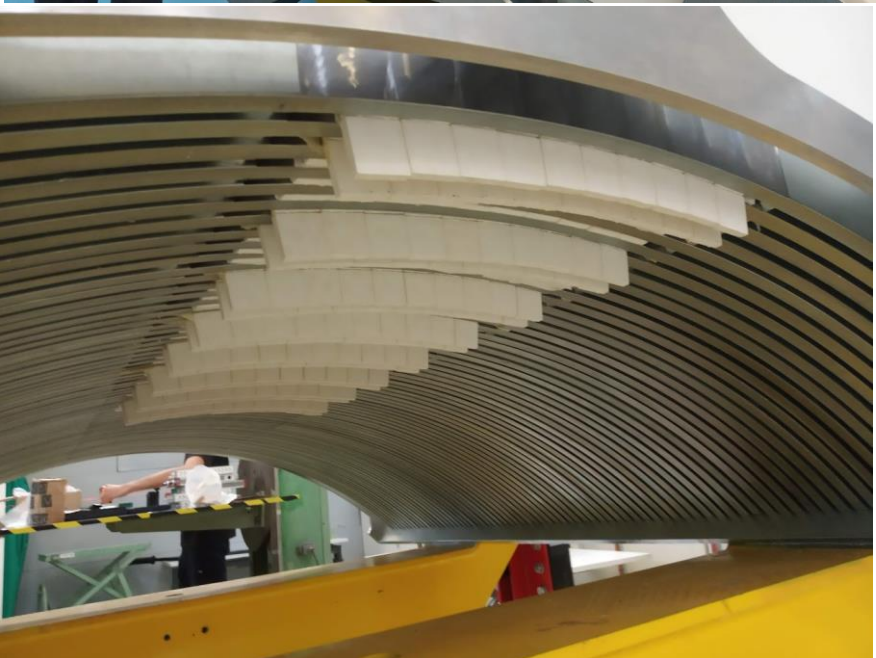


Lifting test of demonstrator

Play (k)



The ENUBET demonstrator: at CERN PS-EA right now!



16:20 16:20 F ↓ M 0,2KB/s 📶 📶 31

← Post

 francesco.terranova.tel



♡ 💬 📍 🏷

  Piace a valee_terra e altri 18

francesco.terranova.tel An hairy detector for neutrino physics 😄 #enubet #cern

4 ottobre • Vedi la traduzione

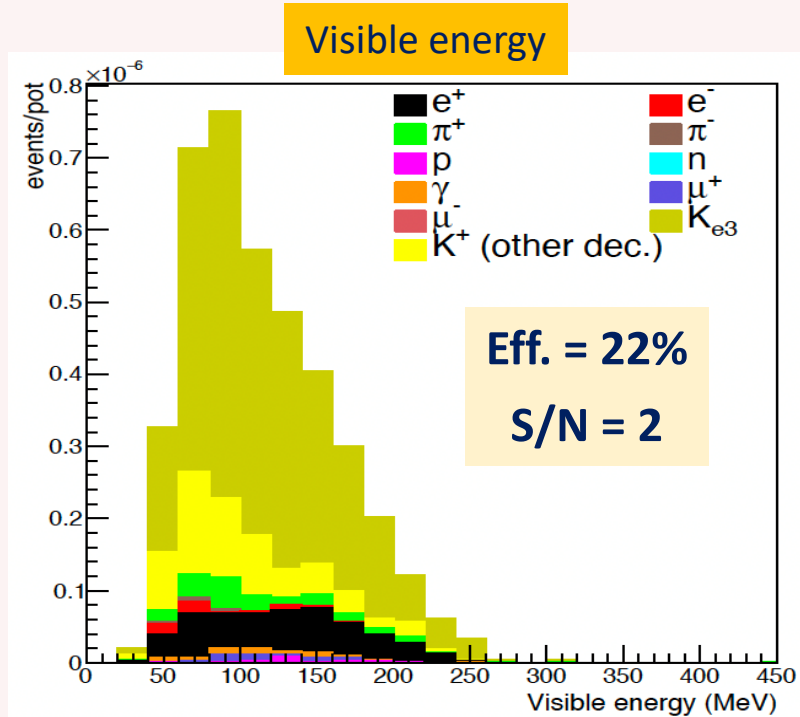
■ ● ◀

Lepton reconstruction and identification performance

Full GEANT4 simulation of the detector: validated by prototype tests at CERN in 2016-2018; hit-level detector response; pile-up effects included (waveform treatment in progress); event building and PID algorithms (2016-2020);

- Large angle positrons and muons from kaon decays reconstructed searching for patterns in energy depositions in tagger;
- Signal identification done using a Neural Network trained on a set of discriminating variables;

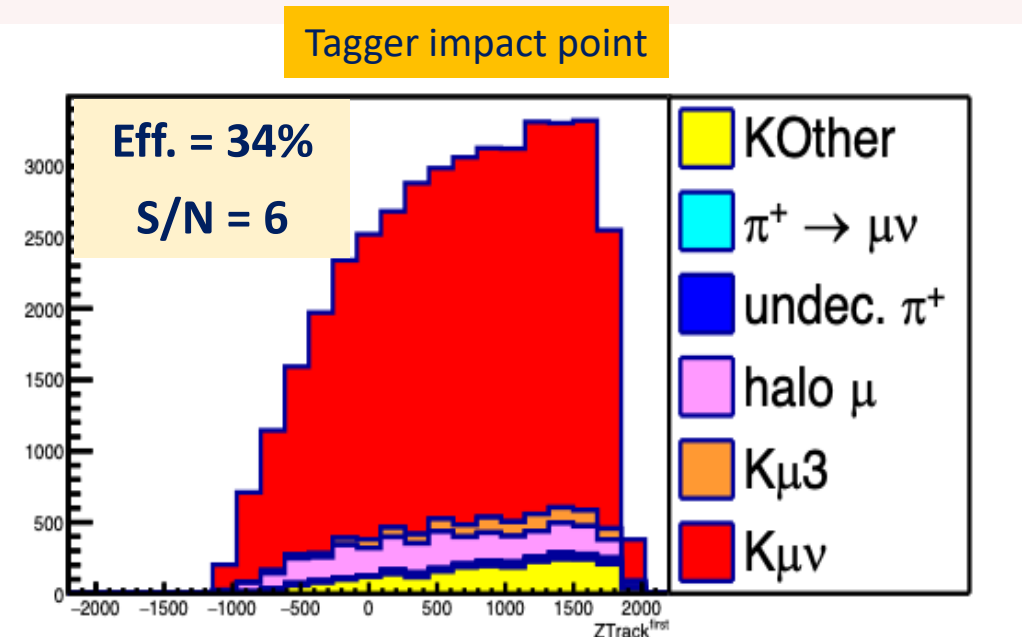
K_{e3} positrons \rightarrow constrain ν_e



Efficiency \sim half geometrical

K_{e3} BR \sim 5% and K make \sim 5 – 10% of beam composition

$K_{\mu 2}$ muons \rightarrow constrain ν_μ

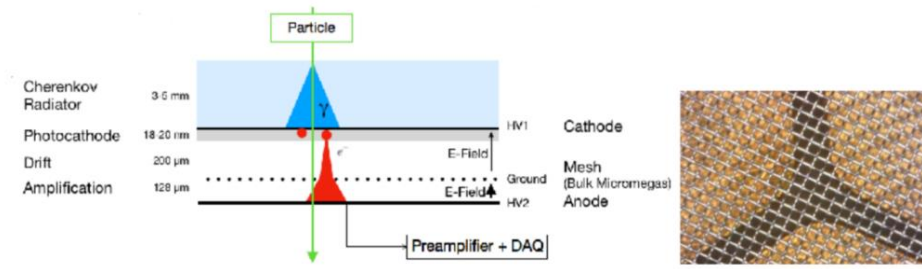


Efficiency \sim half geometrical

Forward lepton reconstruction ($\pi \rightarrow \mu \nu_\mu$)

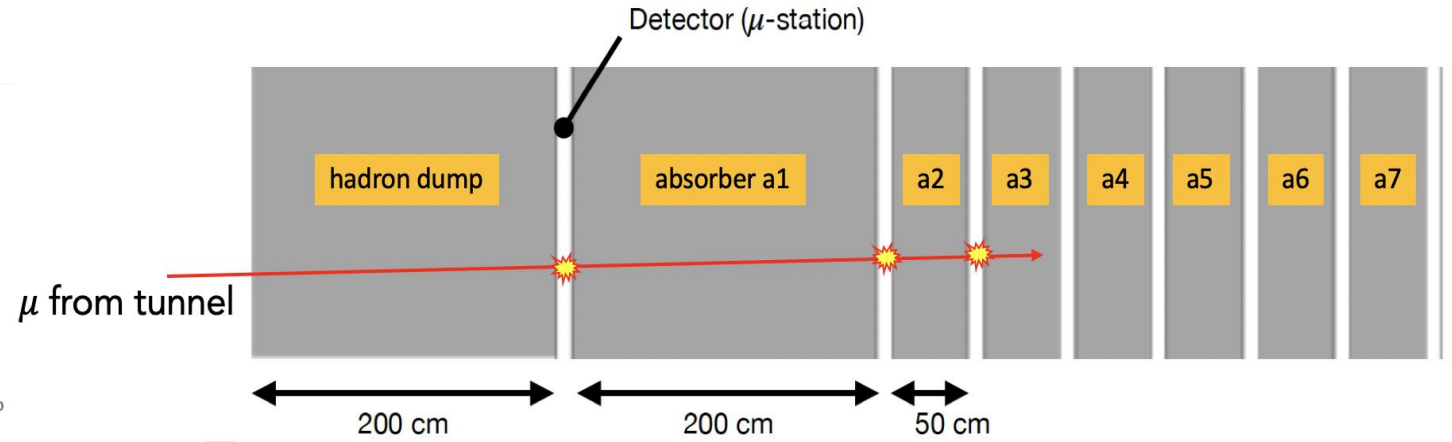
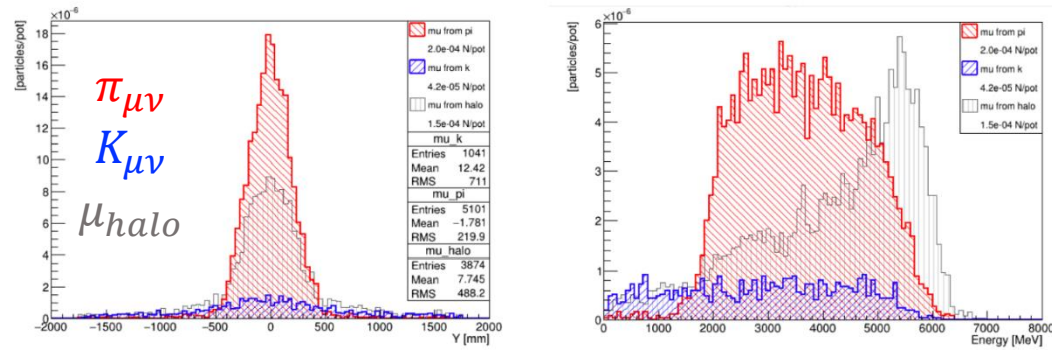
$\pi_{\mu 2}$ muon reconstruction to constrain low-energy ν_μ

✓ **Low angle muons:** out of tagger acceptance, need muon stations after hadron dump



Possible candidates: fast Micromegas detectors with Cherenkov radiators (PIMENT)

Exploit differences in distributions to disentangle components



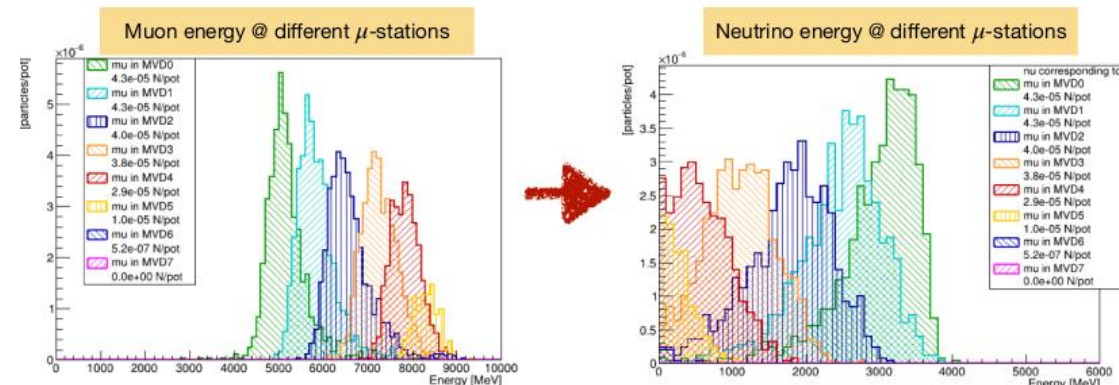
Hottest detector (upstream station): cope with ~ 2 MHz/cm² muon rate and $\sim 10^{12}$ 1 MeV-n_{eq}/cm²

Exploit:

- ❖ correlation between number of traversed stations (muon energy from range-out) and neutrino energy;
- ❖ difference in distribution to disentangle signal from halo-muons;

Detector technology: constrained by muon and neutron rates;

Systematics: punch through, non uniformity, efficiency, halo- μ ;



Project Collaboration

- Partners:
 - Thomas Papaevangelou (CEA/DRF/IRFU)
 - Anselmo Meregaglia (CNRS/IP2I Bordeaux)
 - Dominique Breton (IN2P3/IJCLab)
 - Michal Pomorski (CEA/DRT/LIST)
- Duration: 36 months started from Jan 2022
- External Partners:
 - CERN (L. Ropelewski, E. Oliveri, F. Brunbauer, Rui d'Oliveira, A. Utrobičić, M.Lisowska)
 - University of Thessaloniki (S.Tzamaras, I.Angelis, D.Sampsonidis, K.Kordas, Ch.Lampoudis, A.Tsiamis)
 - USTC Hefei China (Zhou Yi)
 - ENUBET Collaboration (A.Longhin)

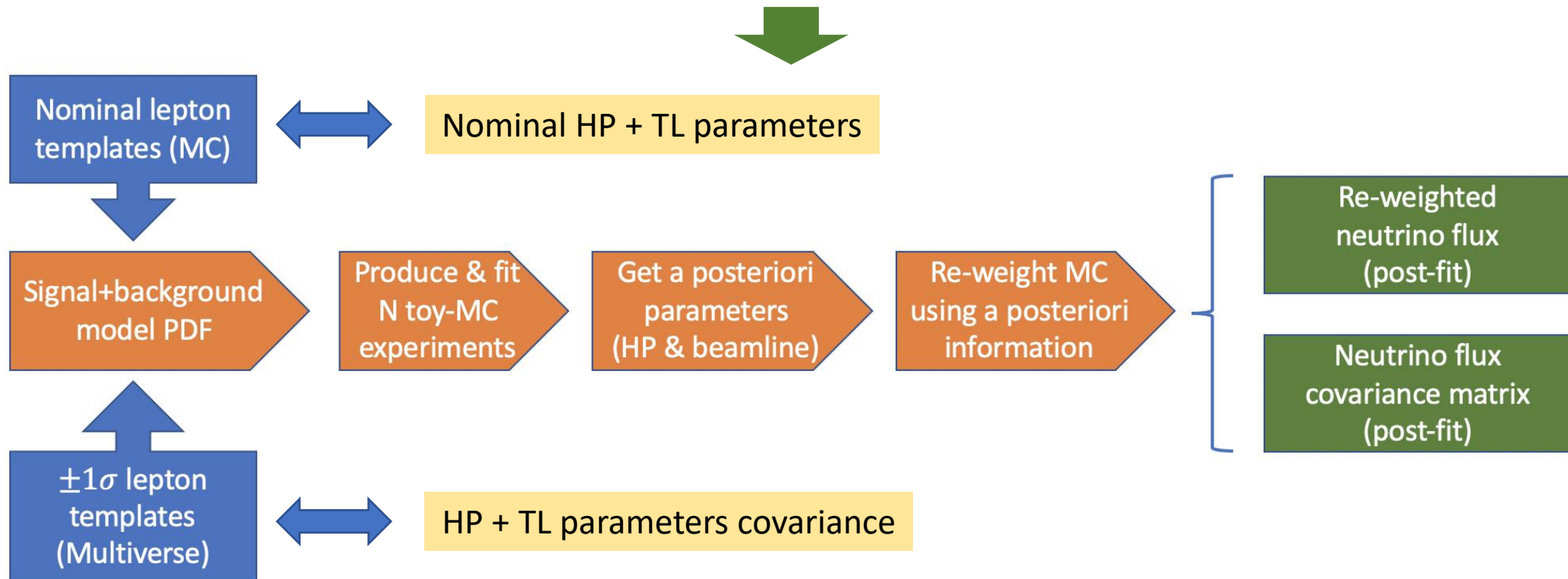
Funded by :



ν -Flux: assessment of systematics

Monitored ν flux from narrow-band beam: measure rate of leptons \Leftrightarrow monitor ν flux

- build a Signal + Background model to fit lepton observables;
- include hadro-production (HP) & transfer line (TL) systematics as nuisances;



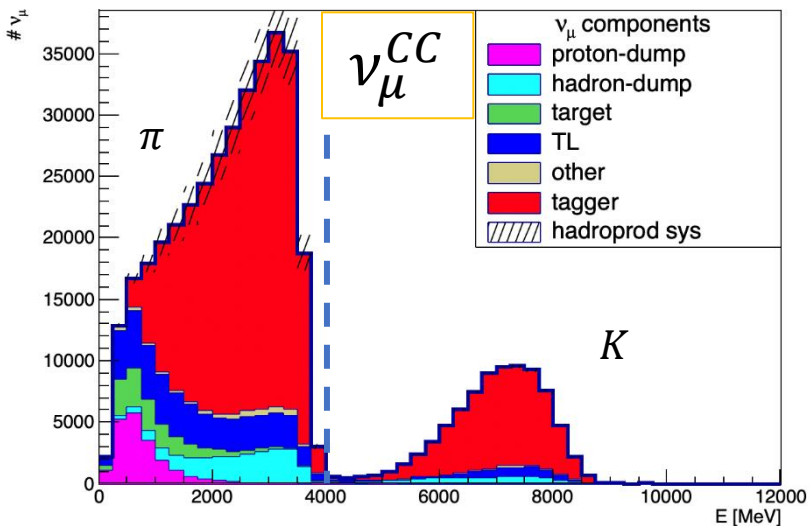
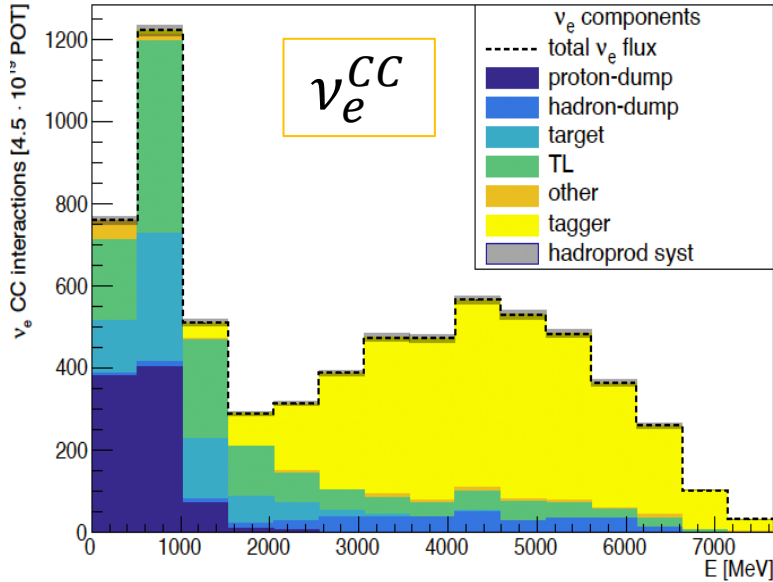
Used **hadro-production** data from NA56/SPY experiment to:

- Reweight MC lepton templates and get their nominal distribution;
- Compute lepton templates variations using multi-universe method;

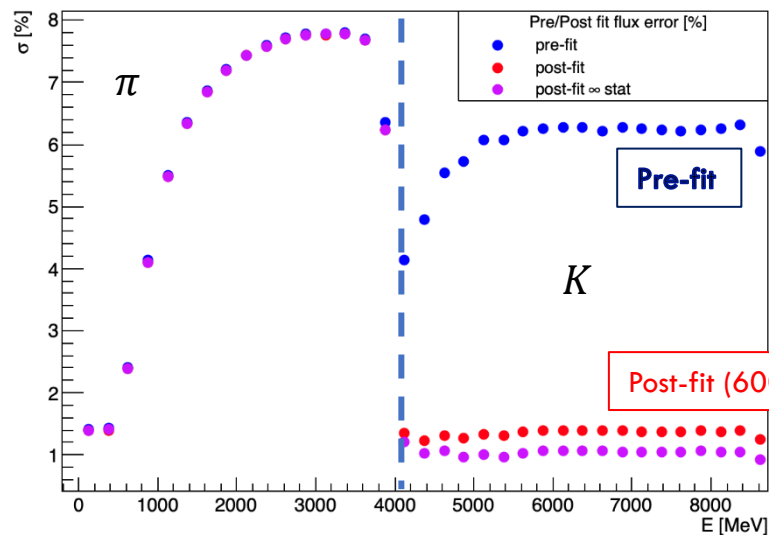
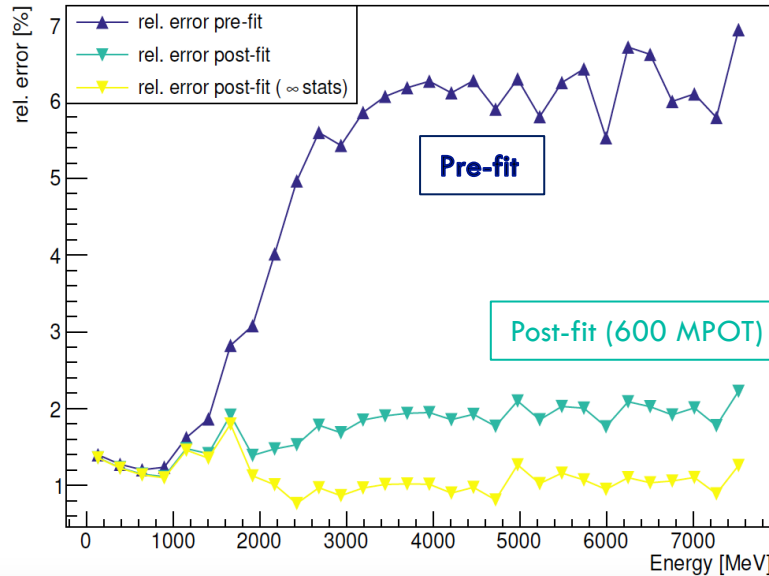
ν -Flux: impact of hadro-production systematics



Neutrino interaction rates @ detector



Pre & Post fit relative errors on rates



Total rates in 1 year of data taking

- @ SPS with $4.5 \cdot 10^{19}$ POT/year;
- 500 ton detector @ 50 m from tunnel end;

Infinite statistics

NEW – Mar 2022 !

Before constraint: 6% systematics due to hadro-production uncertainties;

After constraint: 1% systematics from fit to lepton rates measured by tagger;

Achieved ENUBET goal of 1% systematics from monitoring lepton rates

Infinite statistics

Monitored neutrino beams are viable candidates!



- Measure the neutrino flux of a xsect-dedicated short baseline beam with a precision $<1\%$ in ν_e and ν_μ

OK. ENUBET has achieved a precision of 1% considering the leading systematics and only positron monitoring (ICHEP2022). We will publish the final results including the muon constraints and the subdominant contributions in 2023

Room for improvement: reduce the need of protons-on-target to ease implementation at CERN. Enhance statistics in the region of interest for HyperK

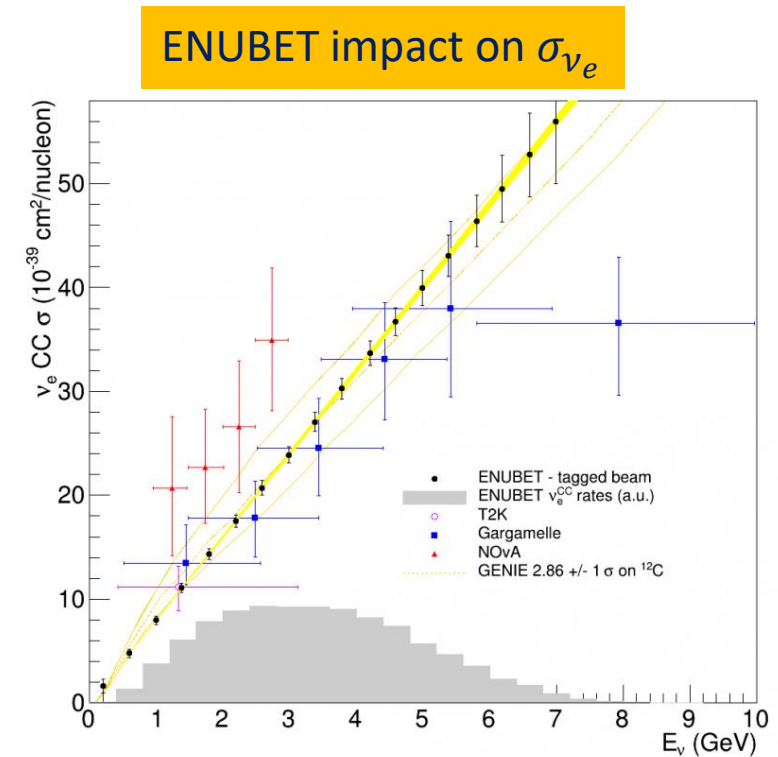
- Measure the energy of the neutrino without relying on the final state to get rid of all biases coming from nuclear reinteractions

OK. Using the fact that the ENUBET beam is narrow band we achieve an event-to-event resolution of 8% at 3 GeV and 25% at 1 GeV (“NBOA” technique)

Room for improvement: a direct muon energy measurement can improve substantially this precision, especially at low E (tracking at the last dipole) [Nutech, NuTAG, PIMENT, Pine]

- Use the same target ad DUNE and HyperK + low Z target (existing or new experiments)

YES. All results above work with a 400 ton detector. ProtoDUNE-SP at CERN is a major asset **but** a full site-dependent (SPS@CERN) study is not available yet.



Toward a SBL neutrino beam at CERN



A successful R&D is not enough to propose a short baseline neutrino beam at CERN in 2029 (Run 4 of LHC, in parallel with the run of DUNE and HyperK). We need:

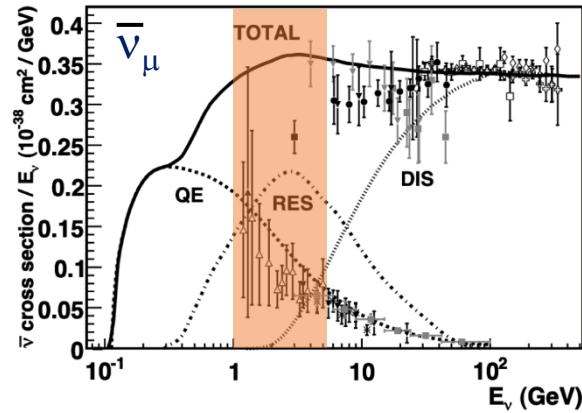
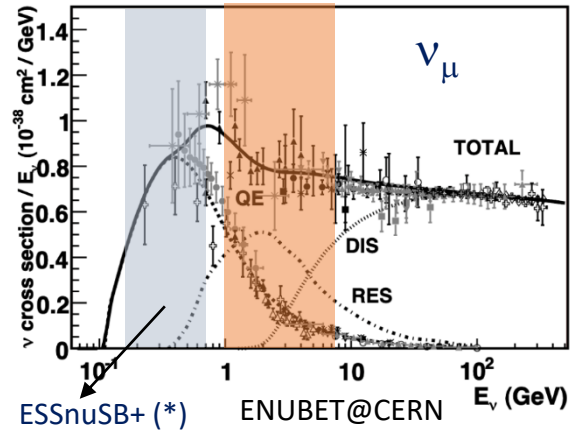
- To create **consensus** in the neutrino community. Detail the physics case and the detector requirements
- To be **realistic** as regards the site implementation. We need $5-9 \cdot 10^{19}$ proton-on-target in 2-5 years and a location that can fit a suite of detectors, possibly including ProtoDUNE-SP and ProtoDUNE-DP (now called “ProtoDUNE-VD”).
- To **be optimistic** 😊 The physics case is strong and already attracted the interest of NUSTEC, DUNE, and HyperKamiokande. We need to transform this generic interest in a real proposal by 2025

Framework:

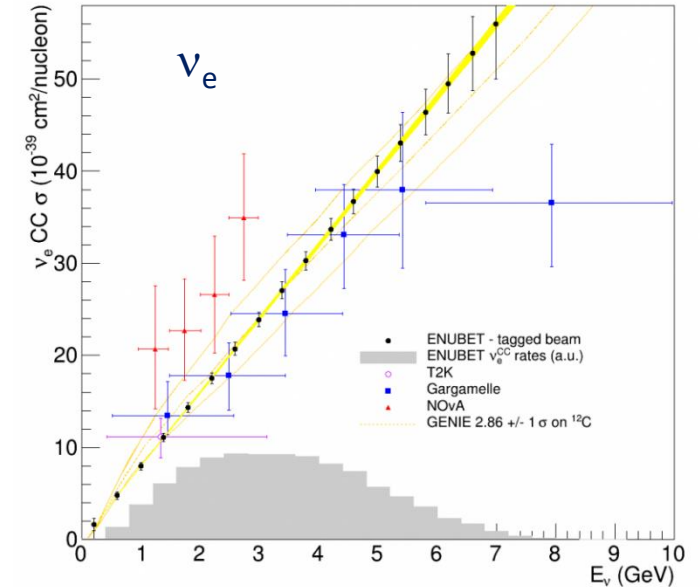
- We are carrying on the beam optimization (pot reduction, energy measurement) and site-dependent study in the framework of **Physics Beyond Collider** at CERN
- We are detailing the physics case with **nuSTORM** because many items are in common
- The ENUBET physicists are deeply involved in **DUNE and HyperK** and they are aware of the needs of these experiments and complementarity with the Near Detector measurements

Physics case: SM physics

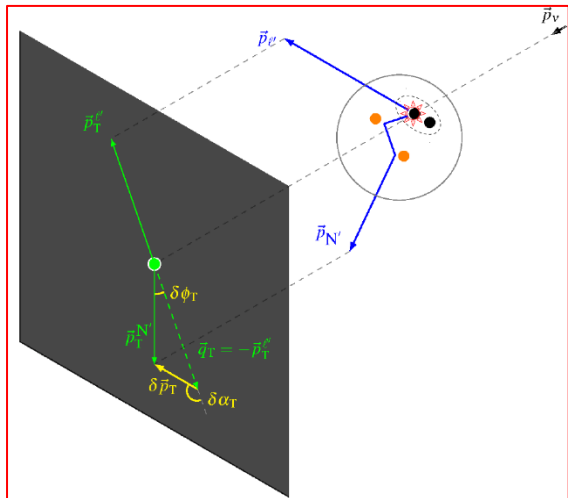
Inclusive neutrino cross section: solid results already available



(*) monitored neutrino beam
@ESS Design studied approved by
EU (lead CNRS) in July 2022



Differential cross sections:

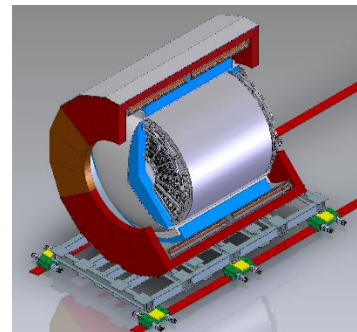


Exploit the knowledge of the neutrino energy without relying on final states: ENUBET NBOA + transverse kinematic embalance (*)

(*) X.G. Lu et al. PRC 94 (2016) 105503

Low Z and low-density targets:

- M. Hartz et al., CERN-SPSC-2020-005; SPSC-P-365
- A. Abed Abud, arXiv:2203.06281
- L. Alvarez-Rouso et al., arXiv:2203.11298
- H. Duyang et al., PLB 795 (2019) 424



Physics case: BSM physics and parasitic measurements



Sterile neutrinos: some results already available

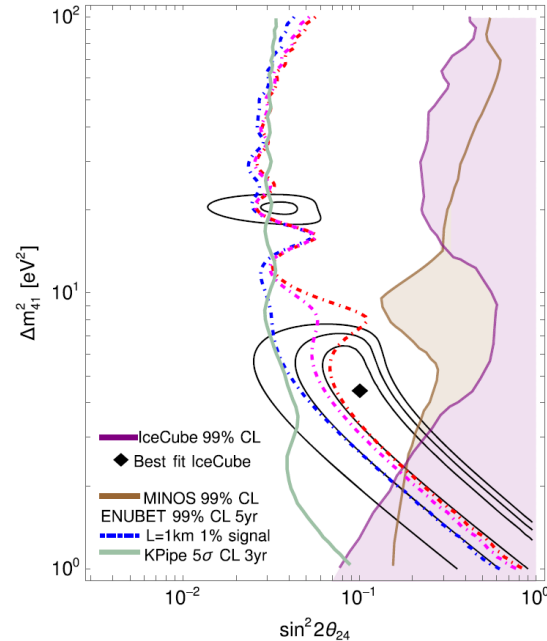
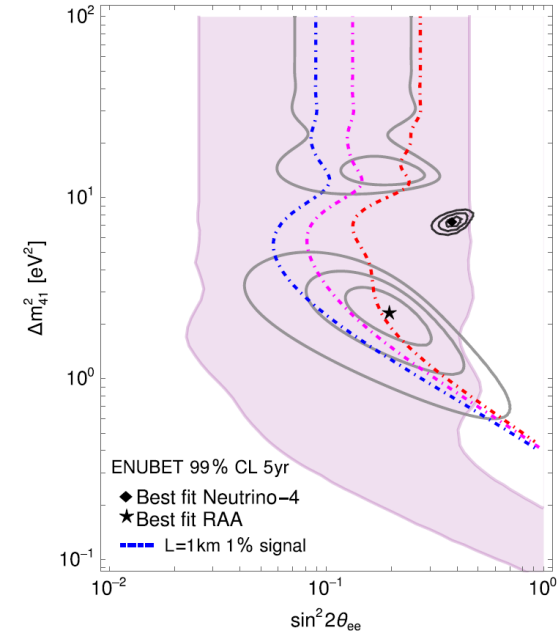
L.A. Delgado, P. Huber, PRD 103 (2021) 035018

Non-Standard interactions: to be investigated

Instrumented proton and hadron dump:

P. S. Bhupal Dev, Doojin Kim, K. Sinha, Yongchao Zhang, Phys. Rev. D 104, 035037 [ALP]

J. Spitz, Phys. Rev. D 89 (2014) 073007 [KDAR]



Work ongoing for studies of Dark Sector and non-standard neutrino interactions to assess potential of SBL versus Near detectors:

Pro: energy control of the incoming flux. Outstanding precision on the flux and flavor composition

Cons: Limited statistics

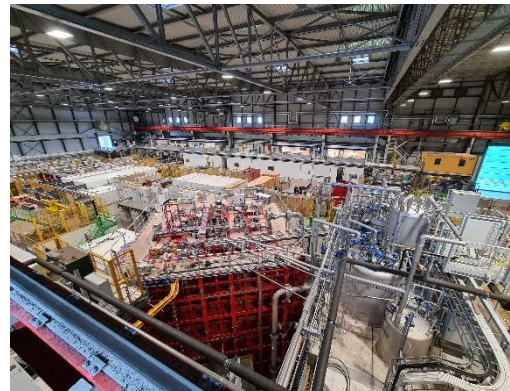
The CERN facilities



A short baseline neutrino beam at the SPS was studied in detail in 2010-12 for sterile neutrino searches (ICARUS-NESSIE Collaboration, 100 GeV protons from SPS – M. Antonello et al., CERN-SPSC-2012-010).

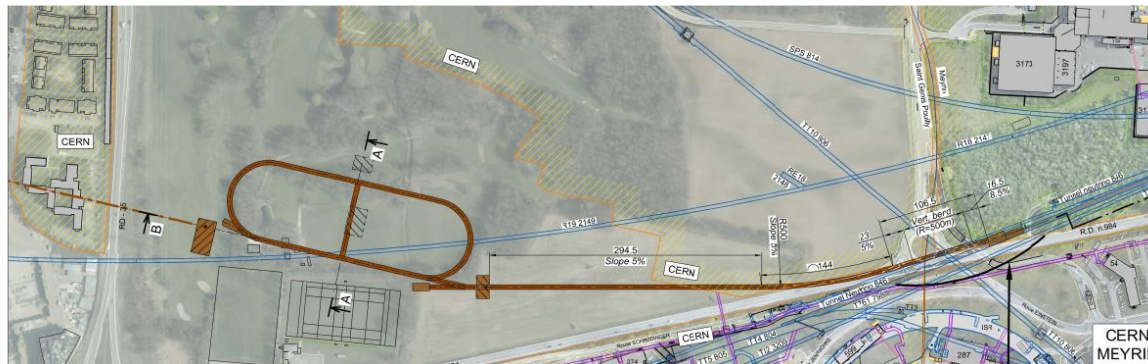
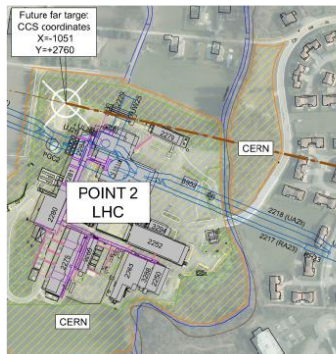


Figure 1. The new SPS North Area neutrino beam layout. Main parameters are: primary beam : 100 GeV; fast extracted from SPS; target station next to TCC2, ~11m underground; decay pipe: 100m, 3 m diameter; beam dump : 15m of Fe with graphite core, followed by muon stations; neutrino beam angle: pointing upwards; at -3m in the far detector ~5mrad slope. From I. Efthymiopoulos / CERN.



This area now hosts the EHN1 extension and is served by a dedicated (low intensity!) charged particle beamline: a tertiary extension branch of the H4 beam line in the CERN North Area (H4-VLE).

A design study compatible with ENUBET but aimed at nuSTORM was carried out in 2019 for a possible implementation of nuSTORM at CERN (C.C. Ahida et al., CERN-PBC-REPORT-2019-003)



It exploits an existing transfer line in the Meyrin site (TT60) and requires a dedicated detector site.

The CERN (site dependent) study



Three options are currently under consideration:

- The cheapest: a dedicated neutrino beamline extracted from the North area and pointing toward ProtoDUNE
 - Maximum use of existing facilities
 - Slow extraction easily implemented
 - Strong interference with other experiments
 - Potential radiation issues
- The cleanest: a dedicated extraction line near the North area pointing to ProtoDUNE
 - No interference with experiments and existing facilities
 - Minor radiation issues
 - Slow extraction
 - Higher cost
- The nuSTORM-like extraction line
 - Relatively cheap
 - Incompatible with ProtoDUNE in their current position
 - Potential issues with the slow extraction

Conclusions



- Monitored neutrino beams are no more an “interesting idea”: the proof-of-concept is nearly complete and NP06/ENUBET has proven it both by simulations and a full experimental validation
- A monitored neutrino beam has all features needed for a new generation of cross section experiments
- The final ENUBET results (baseline beamline, multi-momentum beamline, systematic assessment, and performance of the demonstrator) will appear in journals (4 papers) in 2023.
- We have started the process of addressing the real implementation at CERN and aim at a proposal in 2024-2025 to be in data taking for LHC Run IV (2029)
- This is a major effort that requires:
 - Careful assessment of physics performance
 - Assets and limitations for the use of ProtoDUNE (e.g. cosmic rejection in a slow extraction, kinematic reconstruction of final states, etc.)
 - Optimal location at CERN to exploit the SPS slow extraction

We look forward to your suggestions for a design that fulfill the needs of the neutrino and nuclear physicists to have these experiment up and running in parallel with DUNE and HyperK